

## INSTRUCTIONS



EVIS EXERA DUODENOVideoscope  
**OLYMPUS TJF TYPE 160VR**

Refer to the endoscope's companion manual, the "OLYMPUS TJF TYPE 160VR REPROCESSING MANUAL" for reprocessing information.





# Contents

<b>Symbols</b> .....	<b>1</b>
<b>Important Information — Please Read Before Use</b> .....	<b>2</b>
Intended use .....	2
Applicability of endoscopy and endoscopic treatment .....	2
Instruction manual.....	3
User qualifications .....	3
Instrument compatibility .....	3
Reprocessing before the first use/reprocessing and storage after use.....	4
Spare equipment .....	4
Repair and modification .....	4
Signal words .....	4
Warnings and cautions.....	5
Examples of inappropriate handling .....	7
<b>Chapter 1 Checking the Package Contents</b> .....	<b>8</b>
<b>Chapter 2 Instrument Nomenclature and Specifications</b> .....	<b>10</b>
2.1 Nomenclature.....	10
2.2 Endoscope functions.....	12
2.3 Specifications.....	14
<b>Chapter 3 Preparation and Inspection</b> .....	<b>17</b>
3.1 Preparation of the equipment.....	18
3.2 Inspection of the endoscope .....	19
3.3 Preparation and inspection of accessories .....	23
3.4 Attaching accessories to the endoscope .....	28
3.5 Inspection and connection of ancillary equipment .....	37
3.6 Inspection of the endoscopic system .....	39
<b>Chapter 4 Operation</b> .....	<b>44</b>
4.1 Insertion .....	46
4.2 Using endo-therapy accessories.....	52
4.3 Withdrawal of the endoscope.....	61
4.4 Transportation of the endoscope .....	62

<b>Chapter 5 Troubleshooting .....</b>	<b>63</b>
5.1 Troubleshooting guide .....	63
5.2 Withdrawal of the endoscope with an abnormality.....	67
5.3 Returning the endoscope for repair.....	69
<b>Appendix.....</b>	<b>71</b>
System chart .....	71
EMC information.....	80

# Symbols

The meaning(s) of the symbol(s) shown on the package with the components, the back cover of this instruction manual and/or this instrument are as follows:



Refer to instructions.



Endoscope



TYPE BF applied part



Manufacturer



Authorized representative in the European Community

# ***Important Information — Please Read Before Use***

## ***Intended use***

This instrument has been designed to be used with an Olympus video system center, light source, documentation equipment, video monitor, endo-therapy accessories (such as a biopsy forceps) and other ancillary equipment for endoscopy and endoscopic surgery within the duodenum.

Do not use this instrument for any purpose other than its intended use.

## ***Applicability of endoscopy and endoscopic treatment***

If there is an official standard on the applicability of endoscopy and endoscopic treatment that is defined by the hospital's administration or other official institutions such as academic societies on endoscopy, follow that standard. Before starting endoscopy and endoscopic treatment, thoroughly evaluate its properties, purposes, effects, and possible risk (their natures, extent and probability). Perform endoscopy and endoscopic treatment only when its potential benefits are greater than its risks.

Fully explain to the patient the potential benefits and risks of the endoscopy and endoscopic treatment as well as any examination/treatment methods that can be performed in its place, and perform the endoscopy and endoscopic treatment only after obtaining the consent of the patient.

Even after starting the endoscopy and endoscopic treatment, continue to evaluate the potential benefits and risks, and immediately stop the endoscopy/treatment and take proper measures if the risks to the patient become greater than the potential benefits.

## ***Instruction manual***

This instruction manual contains essential information on using this instrument safely and effectively. Before use, thoroughly review this manual and the manuals of all equipment which will be used during the procedure and use the equipment as instructed.

Note that the complete instruction manual set for this endoscope consists of this manual and the “REPROCESSING MANUAL” whose cover lists the model of your endoscope. It also accompanied the endoscope at shipment.

Keep this and all related instruction manuals in a safe, accessible location.

If you have any questions or comments about any information in this manual, please contact Olympus.

## ***User qualifications***

The operator of this instrument must be a physician or medical personnel under the supervision of a physician and must have received sufficient training in clinical endoscopic technique. This manual, therefore, does not explain or discuss clinical endoscopic procedures. For details on clinical endoscopic procedures, the physician and operator are requested to form judgments from their viewpoints as specialists.

## ***Instrument compatibility***

Refer to the “System chart” in the Appendix to confirm that this instrument is compatible with the ancillary equipment being used. Using incompatible equipment can result in patient or operator injury and/or equipment damage.

This instrument complies with EMC standard for medical electrical equipment; edition 2 (IEC 60601-1-2: 2001). However, when connected with an instrument that complies with EMC standard for medical electrical equipment; edition 1 (IEC 60601-1-2: 1993), the whole system complies with edition 1.

## ***Reprocessing before the first use/reprocessing and storage after use***

This instrument was not cleaned, disinfected or sterilized before shipment. Before using this instrument for the first time, reprocess it according to the instructions given in the endoscope's companion manual, the "REPROCESSING MANUAL" whose cover lists the model of your endoscope. After using this instrument, reprocess and store it according to the instructions given in the endoscope's companion reprocessing manual. Improper and/or incomplete reprocessing or storage can present an infection-control risk, cause equipment damage or reduce performance.

## ***Spare equipment***

Be sure to prepare another endoscope to avoid that the examination will be interrupted due to equipment failure or malfunction.

## ***Repair and modification***

This instrument does not contain any user-serviceable parts. Do not disassemble, modify or attempt to repair it; patient or operator injury and/or equipment damage can result. This instrument is to be repaired by Olympus technicians only.

## ***Signal words***

The following signal words are used throughout this manual:

### **WARNING**

Indicates a potentially hazardous situation which, if not avoided, could result in death or serious injury.

### **CAUTION**

Indicates a potentially hazardous situation which, if not avoided, may result in minor or moderate injury. It may also be used to alert against unsafe practices or potential equipment damage.

### **NOTE**

Indicates additional helpful information.



## **Warnings and cautions**

Follow the warnings and cautions given below when handling this instrument. This information is to be supplemented by the warnings and cautions given in each chapter.

### **WARNING**

- After using this instrument, reprocess and store it according to the instructions given in the endoscope's companion reprocessing manual. Using improperly or incompletely reprocessed or stored instruments may cause patient cross-contamination and/or infection.
- Do not strike, bend, hit, pull, twist, or drop the endoscope's distal end, insertion tube, bending section, control section, universal cord, or endoscope connector of the endoscope with excessive force. The endoscope may be damaged and could cause patient injury, burns, bleeding and/or perforations. It could also cause parts of the endoscope to fall off inside the patient.
- Never perform angulation control forcibly or abruptly. Never forcefully pull, twist or rotate the angulated bending section. Patient injury, bleeding and/or perforation can result. It may also become impossible to straighten the bending section during an examination.
- Never insert or withdraw the endoscope's insertion tube while the bending section is locked in position. Patient injury can result.
- Do not touch the light guide of the endoscope connector immediately after removing it from the light source because it is extremely hot. Operator or patient burns can result.
- Do not twist the insertion tube within a narrow tube. This could cause the distal cover to come off.
- Never operate the bending section, feed air or perform suction, insert or withdraw the endoscope's insertion tube, without viewing the endoscopic image. Never use endo-therapy accessories without viewing the endoscopic image. Patient injury can result.
- Never operate the bending section, feed air or perform suction, insert or withdraw the endoscope's insertion tube while the image is frozen. Never use endo-therapy accessories while the image is frozen. Patient injury, can result.

- Never insert or withdraw the endoscope's insertion tube with excessive force. Otherwise, patient injury could result.

**CAUTION**

- Do not pull the universal cord during an examination. The endoscope connector will be pulled out from the output socket of the light source and the endoscopic image will not be visible.
- Do not coil the insertion tube or universal cord into a diameter of less than 12 cm. Equipment damage can result.
- Do not touch the electrical contacts inside the electrical connector. CCD damage may result.
- Do not apply shock to the distal end of the insertion tube, particularly the objective lens surface at the distal end. Visual abnormalities may result.
- Do not twist or bend the bending section with your hands. Equipment damage may result.
- Do not squeeze the bending section forcefully. The covering of the bending section may stretch or break and cause water leaks.
- Turn the video system center OFF before connecting or disconnecting the videoscope cable from the electrical connector on the endoscope. Turn the switch ON or OFF only when the videoscope cable is connected to both the video system center and electrical connector on the endoscope. Failure to do so can result in equipment damage, including destruction of the CCD.
- The endoscope's remote switches cannot be removed from the control section. Pressing, pulling or twisting them with excessive force can break the switches and/or may cause water leaks.
- If remote switch 1 does not return to the OFF position after being pressed strongly from the side, gently pull the switch upwards to return it to the OFF position.
- Do not hit or bend the electrical contacts on the endoscope connector. The connection to the light source may be impaired and faulty contact can result.
- Do not attempt to bend the endoscope's insertion tube with excessive force. Otherwise, the insertion tube may be damaged.

- The endoscope contains a memory chip that stores information about the endoscope and communicates this information to the CV-160. Although the memory chip is durable, damage will prevent data from being backed up on it. When data are lost or damaged, contact Olympus.
- Electromagnetic interference may occur on this instrument near equipment marked with the following symbol or other portable and mobile RF (Radio Frequency) communications equipment such as cellular phones. If electromagnetic interference occurs, mitigation measures may be necessary, such as reorienting or relocating this instrument, or shielding the location.



## ***Examples of inappropriate handling***

Details on clinical endoscopic technique are the responsibility of trained specialists. Patient safety in endoscopic examinations and endoscopic treatment can be ensured through appropriate handling by the physician and the medical facility. Examples of inappropriate handling are given below.

- Over-insufflating the lumen may cause patient pain and/or perforation.
- Applying prolonged suction with the distal end in contact with the mucosal surface may cause bleeding or lesions.
- Retroflexing the endoscope within the esophagus or duodenal bulb may cause mucosal trauma or impaction of the endoscope.
- Inserting, withdrawing and using endo-therapy accessories without a clear endoscopic image may cause burns or perforation.
- Inserting or withdrawing the endoscope, feeding air, applying suction or operating the bending section without a clear endoscopic image may cause patient injury.

# **Chapter 1 Checking the Package Contents**

Match all items in the package with the components shown below. Inspect each item for damage. If the instrument is damaged, a component is missing or you have any questions, do not use the instrument; immediately contact Olympus. This instrument was not disinfected or sterilized before shipment. Before using this instrument for the first time, reprocess it according to the instructions given in the endoscope's companion manual, the "REPROCESSING MANUAL" whose cover lists the model of your endoscope.

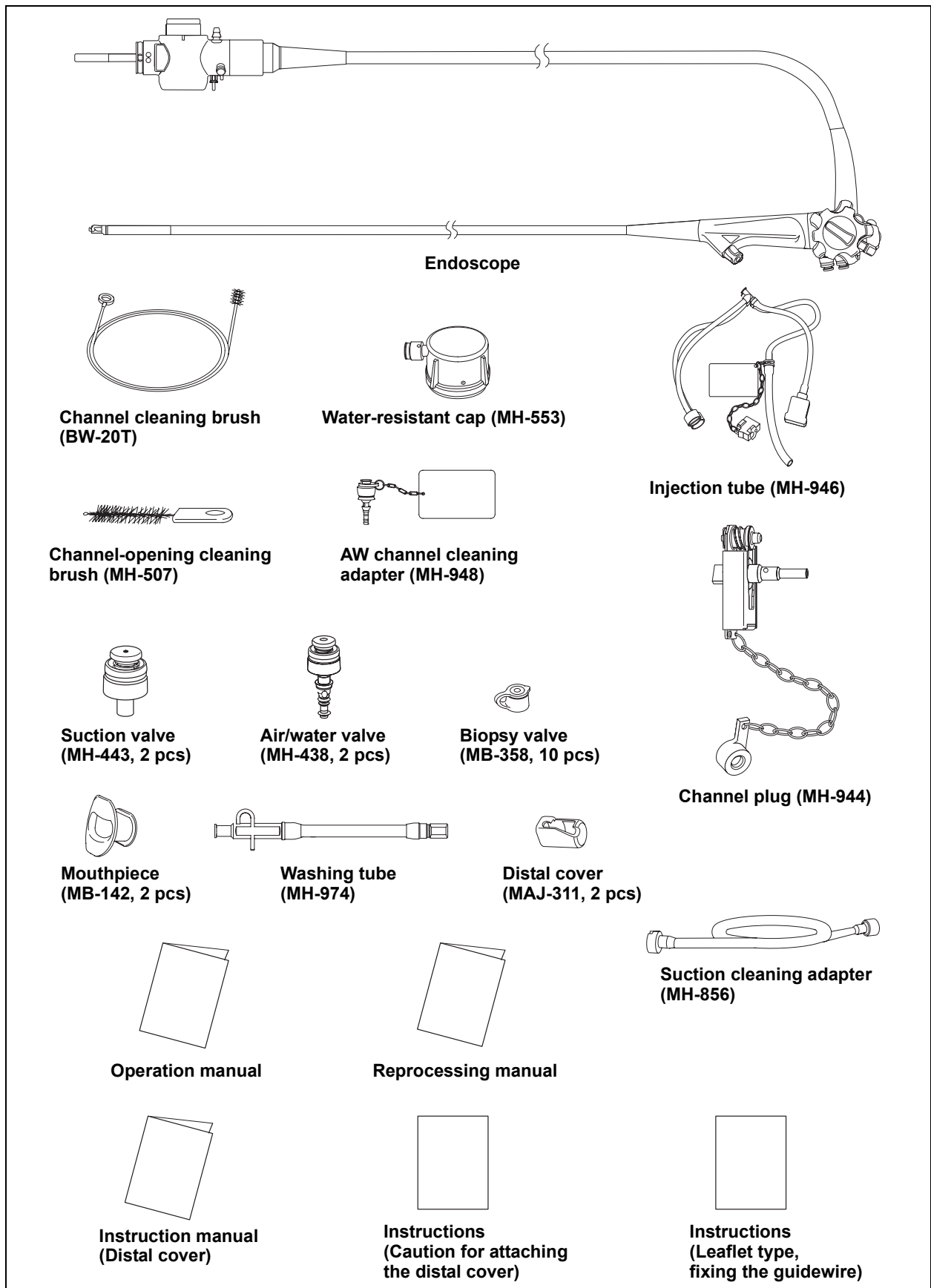

# Chapter 2 Instrument Nomenclature and Specifications

## 2.1 Nomenclature

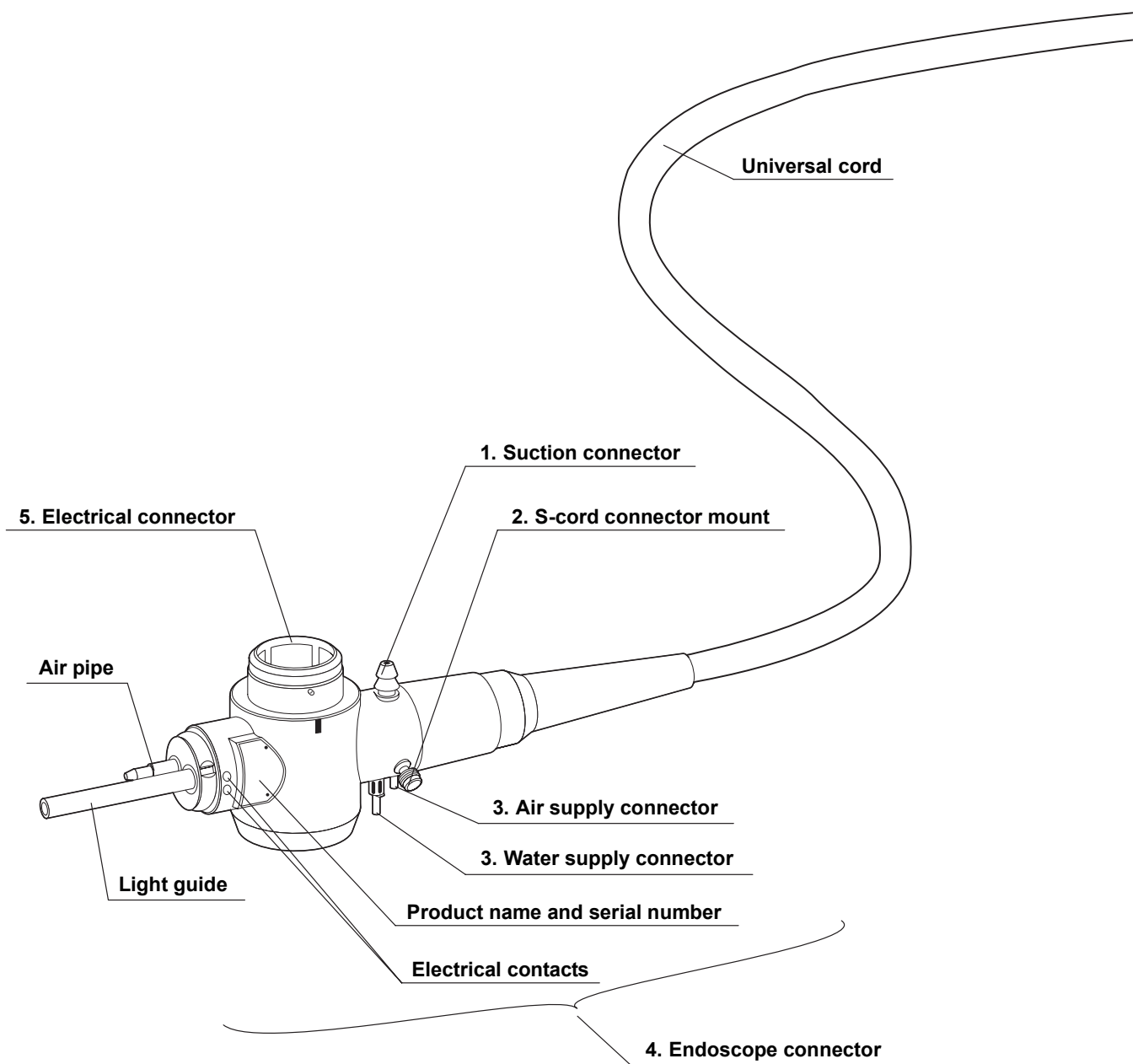

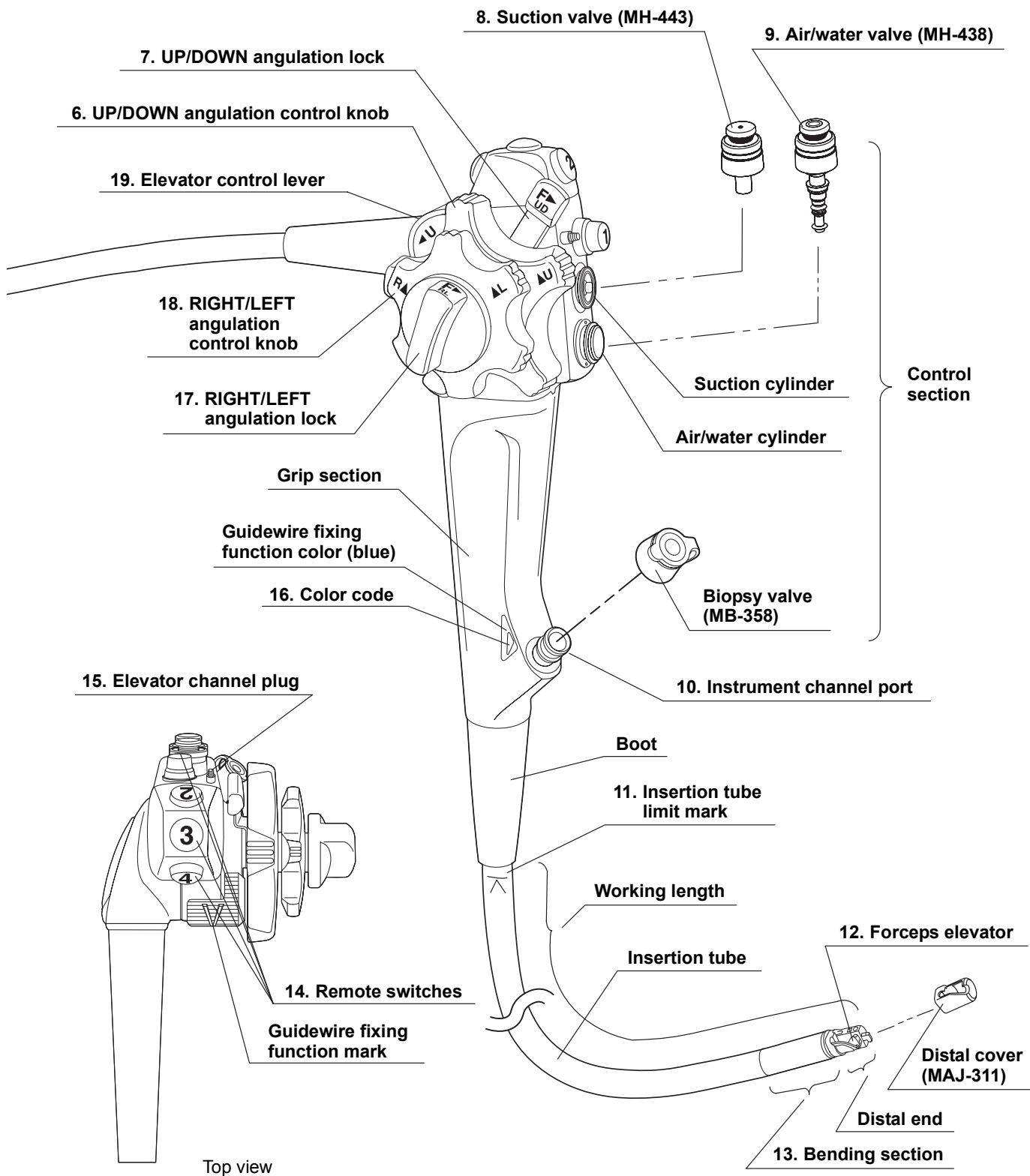

## 2.2 Endoscope functions

### 1. Suction connector

This connector connects the endoscope to the suction tube of the suction pump.

### 2. S-cord connector mount

This mount connects the endoscope with the Olympus electrosurgical unit via the S-cord. The S-cord conducts leakage current from the endoscope to the electrosurgical unit. To connect the S-cord, refer to the instruction manual for the electrosurgical unit.

### 3. Water supply connector and air supply connector

These connectors connect the endoscope to the water container via the water container tube, to supply water to the distal end of the endoscope.

### 4. Endoscope connector

This connector connects the endoscope to the output socket of the light source and transmits light from the light source to the endoscope.

### 5. Electrical connector

This connector connects the endoscope to the video system center via the videoscope cable. The endoscope contains a memory chip that stores information about the endoscope and communicates this information to the video system center CV-160. For more details, refer to the instruction manual of the CV-160.

### 6. UP/DOWN angulation control knob

When this knob is turned in the “▲U” direction, the bending section moves UP; when the knob is turned in the “D▲” direction, the bending section moves DOWN.

### 7. UP/DOWN angulation lock

Moving this lock in the “F▶” direction frees angulation. Moving the lock in the opposite direction locks the bending section at any desired position.

### 8. Suction valve (MH-443)

This valve is depressed to activate suction. The valve is used to remove any fluid, debris, flatus or air from the patient.

### 9. Air/water valve (MH-438)

The hole in this valve is covered to insufflate air and the valve is depressed to feed water for lens washing. It also can be used to feed air to remove any fluid or debris adhering to the objective lens.

### 10. Instrument channel port

The instrument channel port functions as:

- channel for the insertion of endo-therapy accessories
- suction channel
- fluid feed channel (from a syringe via the biopsy valve)



**11. Insertion tube limit mark**

This mark shows the maximum point to which the endoscope may be inserted into the patient's body.

**12. Forceps elevator**

The elevator moves endo-therapy accessories when the elevator control lever is operated. In addition, the forceps elevator is used for assistance of the fixation function of the guidewire while inserting/withdrawing the wire guided type endo-therapy accessory.

**13. Bending section**

This section moves the distal end of the endoscope when the UP/DOWN and RIGHT/LEFT angulation control knobs are operated.

**14. Remote switches 1 to 4**

The functions of remote switches 1 to 4 can be selected on the video system center. When selecting the functions, also refer to the instruction manual for the video system center.

**15. Elevator channel plug**

This plug is used for connection of the washing tube to clean and disinfect the elevator channel.

**16. Color code (orange)**

This code is used to quickly determine the compatibility of endo-therapy accessories. The endoscope can be used with endo-therapy accessories that have the same color code.

**17. RIGHT/LEFT angulation lock**

Turning this lock in the "F▶" direction frees angulation. Turning the lock in the opposite direction locks the bending section at any desired position.

**18. RIGHT/LEFT angulation control knob**

When this knob is turned in the "R▲" direction, the bending section moves RIGHT; when the knob is turned in the "▲L" direction, the bending section moves LEFT.

**19. Elevator control lever**

When this lever is moved in the "◀U" direction, the forceps elevator is raised. When the lever is turned in the opposite direction, the forceps elevator is lowered.

## 2.3 Specifications

### Environment

<b>Operating environment</b>	<b>Ambient temperature</b>	10 – 40°C (50 – 104°F)
	<b>Relative humidity</b>	30 – 85%
	<b>Atmospheric pressure</b>	700 – 1060 hPa (0.7 – 1.1 kgf/cm <sup>2</sup> ) (10.2 – 15.4 psia)
<b>Transportation and storage environment</b>	<b>Ambient temperature</b>	–47 to 70°C (–52.6 to 158°F)
	<b>Relative humidity</b>	10 – 95%
	<b>Atmospheric pressure</b>	700 – 1060 hPa (0.7 – 1.1 kgf/cm <sup>2</sup> ) (10.2 – 15.4 psia)

## Specifications

### ○ Endoscope functions

<b>Model</b>	<b>TJF-160VR</b>	
<b>Optical system</b>	<b>Field of view</b>	100°
	<b>Direction of view</b>	Backward Sideviewing 5°
	<b>Depth of field</b>	5 – 60 mm
<b>Insertion tube</b>	<b>Distal end outer diameter</b>	∅ 13.5 mm
	<b>Distal end enlarged</b>	<ol style="list-style-type: none"> <li>1. Air/water nozzle</li> <li>2. Objective lens</li> <li>3. Light guide lens</li> <li>4. Instrument channel outlet</li> <li>5. Forceps elevator</li> <li>6. Guidewire-locking groove</li> <li>7. Elevator wire</li> <li>8. Hook</li> <li>9. White ring</li> </ol>
	<b>Insertion tube outer diameter</b>	∅ 11.3 mm
	<b>Working length</b>	1240 mm
<b>Instrument channel</b>	<b>Channel inner diameter</b>	∅ 4.2 mm
	<b>Minimum visible distance</b>	10 mm
	<b>Direction from which endo-therapy accessories enter and exit the endoscopic image</b>	

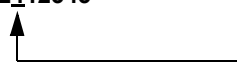
<b>Air flow rate</b>		25 cm <sup>3</sup> /s Note: Standard when CLV-160 (high air pressure) is used.
<b>Bending section</b>	<b>Angulation range</b>	UP 120°, DOWN 90° RIGHT 110°, LEFT 90°
<b>Total length</b>		1550 mm
<b>Medical Device Directive</b>		This device complies with the requirements of Directive 93/42/EEC concerning medical devices. Classification: Class II a
<b>EMC</b>	<b>Applied standard; IEC 60601-1-2: 2001</b>	This instrument complies with the standards listed in the left column.  CISPR 11 of emission:  Group 1, Class B  This instrument complies with the EMC standard for medical electrical equipment; edition 2 (IEC 60601-1-2: 2001). However, when connecting to an instrument that complies with the EMC standard for medical electrical equipment; edition 1 (IEC 60601-1-2: 1993), the whole system complies with edition 1.
<b>Year of manufacture</b>	<b>2412345</b> 	The last digit of the year of manufacture is the second digit of the serial number.
<b>Degree of protection against electric shock</b>		TYPE BF applied part

## **Chapter 3 Preparation and Inspection**

Before each case, prepare and inspect this instrument as instructed below. Inspect other equipment to be used with this instrument as instructed in their respective instruction manuals. If the irregularities are suspected after inspection, follow the instructions given in Chapter 5, “Troubleshooting”. If this instrument malfunctions, do not use it. Return it to Olympus for repair as described in Section 5.3, “Returning the endoscope for repair”.

### **WARNING**

- Using an endoscope that is not functioning properly may compromise patient or operator safety and may result in more severe equipment damage.
- This instrument was not cleaned, disinfected or sterilized before shipment. Before using this instrument for the first time, reprocess it according to the instructions given in the endoscope’s companion manual, the “REPROCESSING MANUAL” whose cover lists the model of your endoscope.

### 3.1 Preparation of the equipment

Prepare the equipment shown in Figure 3.1 (for compatibility, see the “System chart” in the Appendix) and personal protective equipment, such as eye wear, face mask, moisture-resistant clothing and chemical-resistant gloves, before each use. Refer to the respective instruction manuals for each piece of equipment.

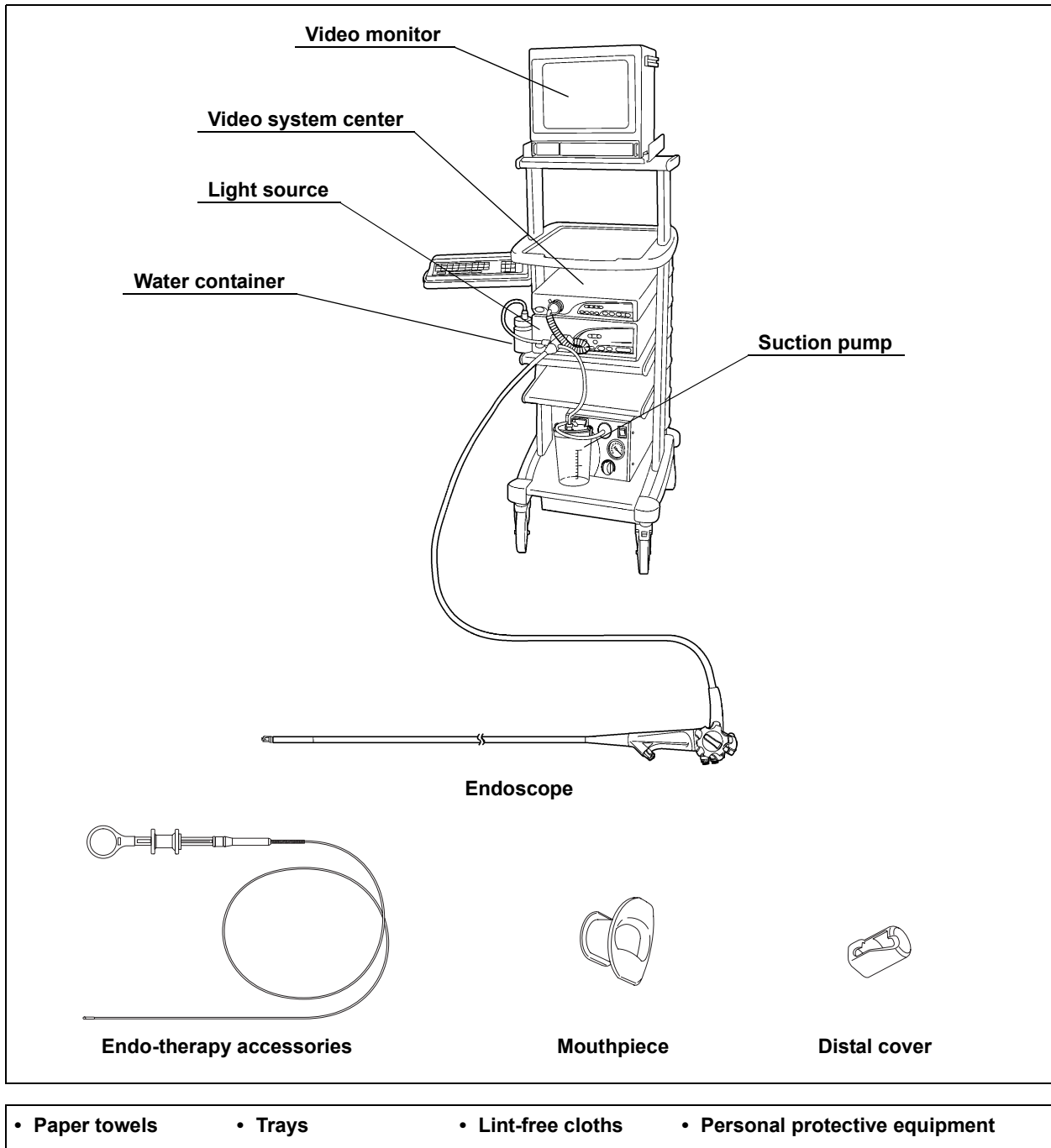

Figure 3.1

## 3.2 Inspection of the endoscope

Clean and disinfect or sterilize the endoscope as described in the “REPROCESSING MANUAL” whose cover lists the model of your endoscope. Then remove the water-resistant cap from the endoscope connector.

### *Inspection of the endoscope*

1. Inspect the control section and the endoscope connector for excessive scratching, deformation, loose parts or other irregularities.
2. Inspect the boot and the insertion tube near the boot for bends, twists or other irregularities.
3. Inspect the external surface of the entire insertion tube including the bending section and the distal end for dents, bulges, swelling, scratching, holes, sagging, transformation, bends, adhesion of foreign bodies, dropout of parts, any protruding objects or other irregularities.
4. Holding the insertion tube gently with one hand, carefully run the fingertips over the entire length of the insertion tube in both directions (see Figure 3.2). Confirm that no object or protrusion of metallic wire around the insertion tube is stopping the hand. Also confirm that the insertion tube is not abnormally rigid.

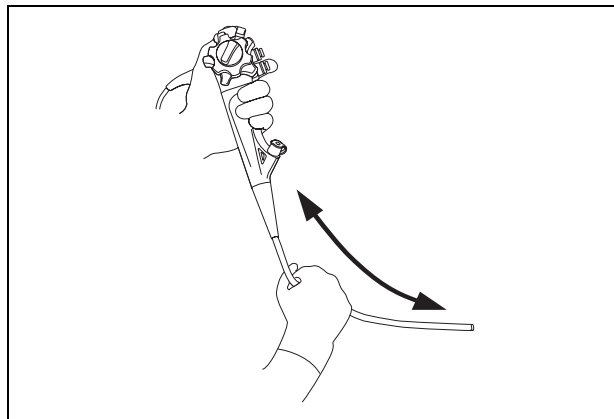

Figure 3.2

5. Using both hands, bend the insertion tube of the endoscope into a semicircle. Then, moving your hands as shown by the arrows, confirm that the entire insertion tube can be smoothly bent to form a semicircle and that the insertion tube is sufficiently pliable (see Figure 3.3).

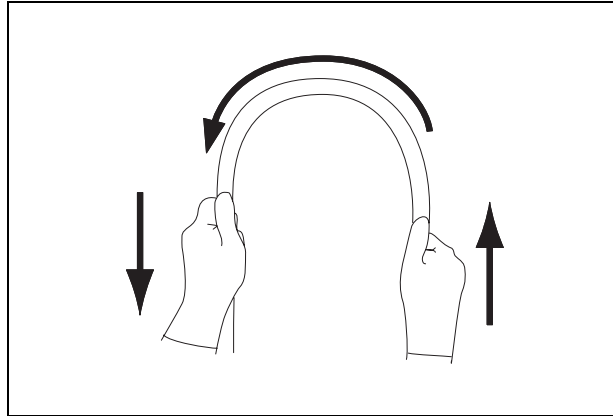

Figure 3.3

6. Gently hold the midpoint of the bending section and a point 20 cm from the distal end. Push and pull gently to confirm that the junction between the bending section and the insertion tube is not loose.
7. Inspect the objective lens and light guide lens at the distal end of the endoscope's insertion tube for scratching, cracks, stains, gaps around the lens or other irregularities.
8. Inspect the air/water nozzle at the distal end of the endoscope's insertion tube for abnormal swelling, bulges, dents or other irregularities.
9. Inspect the guidewire locking groove of the forceps elevator for stain.



## Inspection of the bending mechanisms

Perform the following inspections while the bending section is straight.

### **WARNING**

If the movement of the UP/DOWN angulation lock, RIGHT/LEFT angulation lock and their angulation control knobs are loose and/or not smooth, or the bending section does not angulate smoothly, the bending mechanism may be abnormal. In this case, do not use the endoscope because it may be impossible to straighten the bending section during an examination.

### ○ Inspection for smooth operation

1. Confirm that both the UP/DOWN and RIGHT/LEFT angulation locks move all the way in the “F▶” direction.
2. Turn the UP/DOWN and RIGHT/LEFT angulation control knobs slowly in each direction until they stop, and return to their respective neutral positions. Confirm that the bending section angulates smoothly and correctly, and confirm that maximum angulation can be achieved and return the bending section to its respective neutral positions.
3. When the UP/DOWN and RIGHT/LEFT angulation control knobs are turned to their respective neutral positions as shown in Figure 3.4, confirm that the bending section returns smoothly to an approximately straight condition.

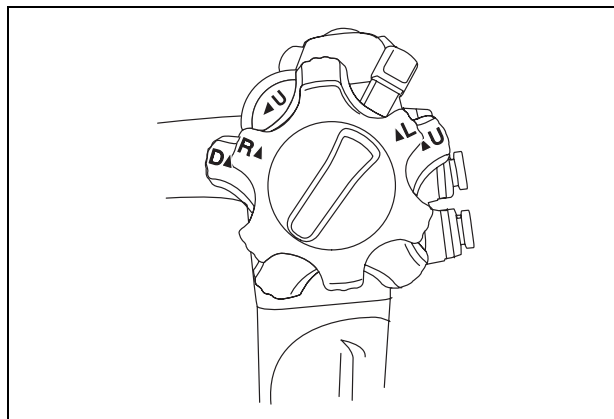

Figure 3.4

### ○ Inspection of the UP/DOWN angulation mechanism

1. Move the UP/DOWN angulation lock all the way in the opposite direction of the “F▶” mark. Then turn the UP/DOWN angulation control knob in the “▲U” or the “D▲” direction until it stops.
2. Confirm that the angle of the bending section is roughly stabilized when the UP/DOWN angulation control knob is released.
3. Confirm that the bending section straightens out when the UP/DOWN angulation lock is moved all the way in the “F▶” direction and the UP/DOWN angulation control knob is released.

### ○ Inspection of the RIGHT/LEFT angulation mechanism

1. Turn the RIGHT/LEFT angulation lock all the way in the opposite direction of the “F▶” mark. Then turn the RIGHT/LEFT angulation control knob in the “R▲” or the “▲L” direction until it stops.
2. Confirm that the angle of the bending section is roughly stabilized when the RIGHT/LEFT angulation control knob is released.
3. Confirm that the bending section straightens out when the RIGHT/LEFT angulation lock is turned in the “F▶” direction and the RIGHT/LEFT angulation control knob is released.

## ***Inspection of the forceps elevator mechanism***

Perform the following inspections while the bending section is straight.

### ○ Inspection for smooth operation

1. Move the elevator control lever slowly all the way in the opposite direction of the “◀U” direction. Visually confirm that the portion of the elevator wire extending from the distal end of the insertion tube is not broken or bent (see Figure 3.5).
2. While observing the forceps elevator at the distal end of the insertion tube, slowly move the elevator control lever all the way in the “◀U” direction. Confirm that the lever can be operated smoothly and that the forceps elevator is raised smoothly. Also confirm that the forceps elevator remains stationary when pushed from behind while holding the elevator control lever stationary (see Figure 3.5).

3. Move the elevator control lever slowly all the way in the opposite direction of the “◀U” direction. Confirm that the lever can be operated smoothly and that the forceps elevator is lowered smoothly (see Figure 3.5).

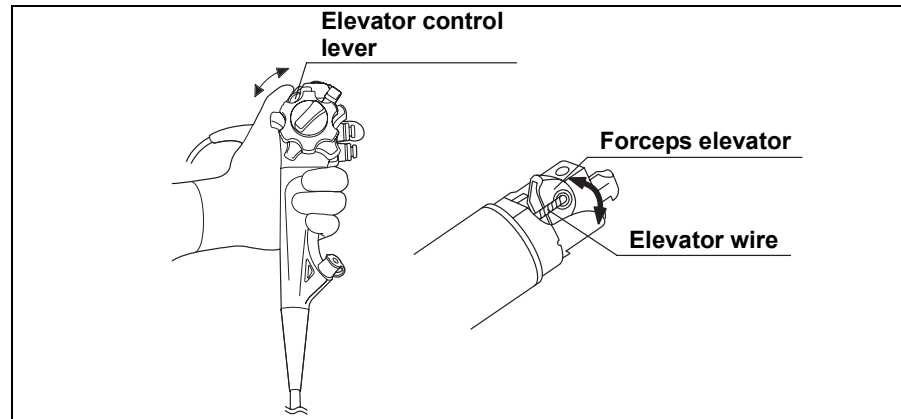

Figure 3.5

### 3.3 Preparation and inspection of accessories

Clean and disinfect or sterilize the air/water valve, suction valve, biopsy valve and distal cover as described in the endoscope's companion reprocessing manual.

#### *Inspection of the air/water and suction valves*

**WARNING**

Confirm that the top hole of the air/water valve is not blocked (see Figure 3.6). If the hole is blocked, air is fed continuously and patient pain, bleeding and/or perforation can result.

1. Confirm that the holes of the valves are not blocked (see Figures 3.6 and 3.7).
2. Confirm that the valves are not deformed or cracked (see Figures 3.6 and 3.7).
3. Check for excessive scratching or tears in the air/water valve's seals (see Figure 3.6).

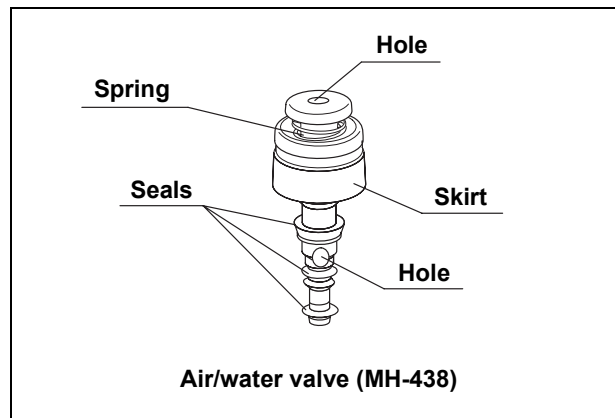

Figure 3.6

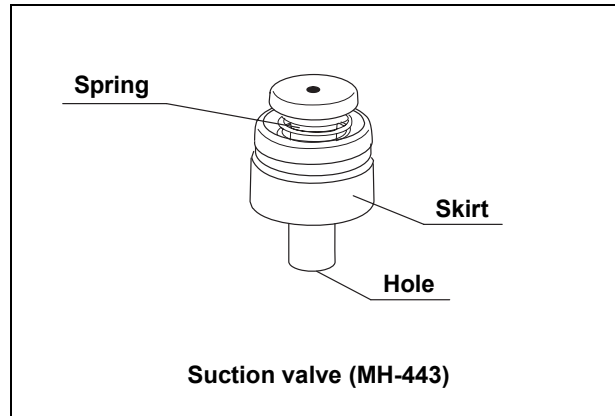

Figure 3.7

**NOTE**

The air/water and suction valves are consumable items. If the inspection of the air/water or suction valve reveals any irregularities, use new valves.

## Inspection of the biopsy valve

### **WARNING**

The biopsy valve is a consumable item that should be inspected before each use. Replace it with a new one if irregularities are observed by following inspection. An irregular, abnormal or damaged valve can reduce the efficacy of the endoscope's suction system, and may leak or spray patient debris or fluids, posing an infection-control risk.

1. Confirm that the slit and hole on the biopsy valves have no splits, cracks, deformation, discoloration or other damage (see Figure 3.8).

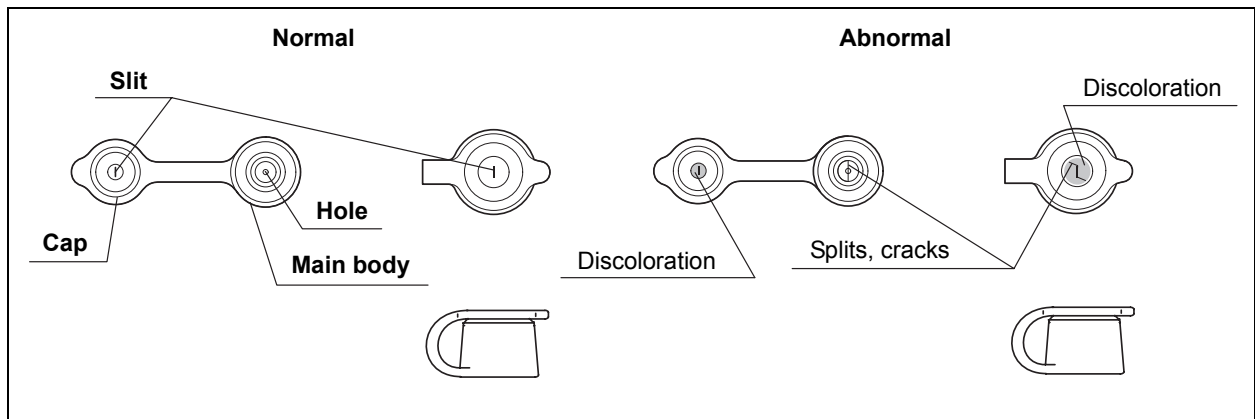

Figure 3.8

2. Attach the cap to the main body (see Figure 3.9).

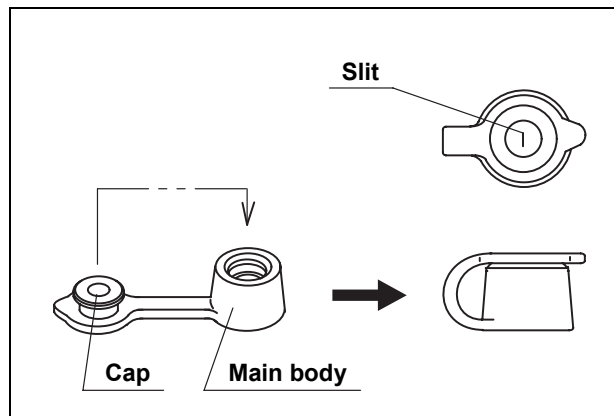

Figure 3.9

## Inspection of the distal cover

### WARNING

- The distal cover has not been sterilized prior to shipping. Using a distal cover that has not been disinfected or sterilized may result in patient infection.
- Should the slightest irregularity be suspected when inspecting the distal cover, do not use it. A defective distal cover could fall off during the examination. Continuing the examination after the distal cover has fallen off may cause patient injury by the exposed distal end of the endoscope.
- Only the distal cover (MAJ-311) can be used with TJF-160VR. If the TJF-160VR is used in combination with a wrong distal cover, it may fall off the distal end during the examination. Continuing the examination after the distal cover has fallen off may cause patient injury by the exposed distal end of the endoscope.

1. Confirm that the metal insert of the distal cover is intact (see Figure 3.10).

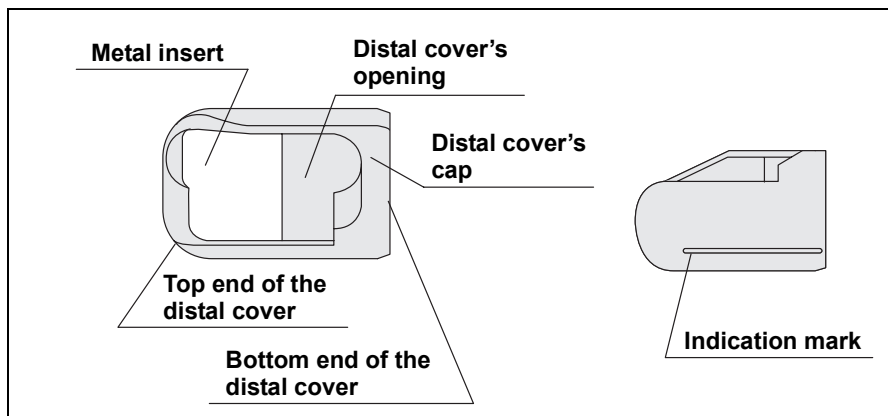

Figure 3.10

2. Confirm that the distal cover's cap has not peeled off of the metal insert.
3. Confirm that the distal cover is free from cracks, wrinkles, discoloration, wear, pinholes or other irregularities.

## ***Inspection of the mouthpiece***

### **CAUTION**

Do not use a mouthpiece that is damaged, deformed or reveals other irregularities. Doing so may cause patient injury and/or equipment damage.

### **NOTE**

Placing the mouthpiece in the patient's mouth before the procedure prevents the patient from biting and/or damaging the endoscope's insertion tube.

1. Confirm that the mouthpiece is free from cracks, deformation or discoloration (see Figure 3.11).
2. Using your fingers, check for excessive scratching or other irregularities on all surfaces of the mouthpiece (see Figure 3.11).

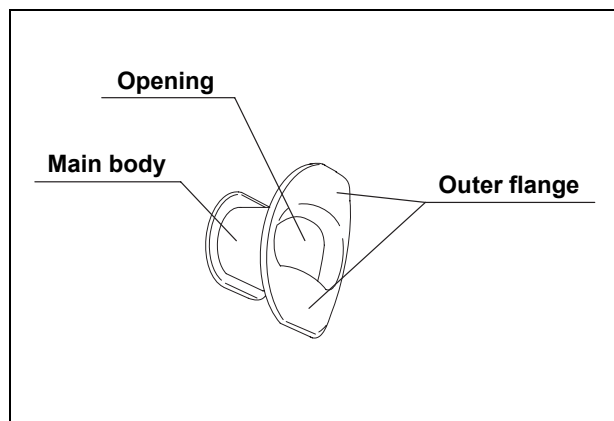

Figure 3.11

## 3.4 Attaching accessories to the endoscope

### CAUTION

The air/water valve and the suction valve do not require lubrication. Lubricants can cause swelling of the valves' seals, which will impair valve function.

### Attaching the suction valve

1. Align the two metal ridges on the underside of the suction valve with the two holes in the suction cylinder.
2. Attach the suction valve to the suction cylinder of the endoscope (see Figures 3.12 and 3.13). Confirm that the valve fits properly without any bulging of the skirt. Also confirm that the valve cannot be rotated.

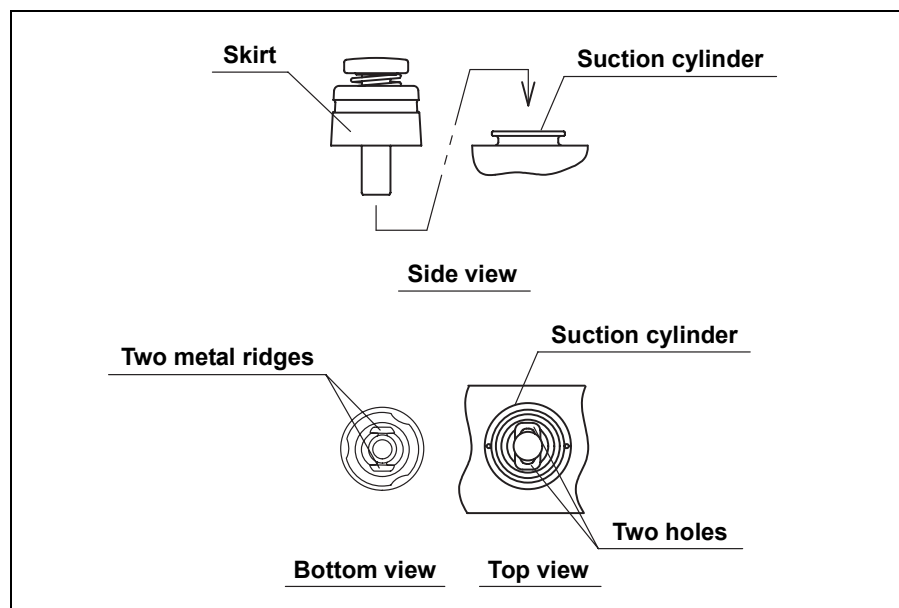

Figure 3.12

### NOTE

The suction valve will make a whistling noise when it is dry; this does not indicate a malfunction.



## Attaching the air/water valve

1. Attach the air/water valve to the air/water cylinder of the endoscope (see Figure 3.13).
2. Confirm that the valve fits properly without any bulging of the skirt.

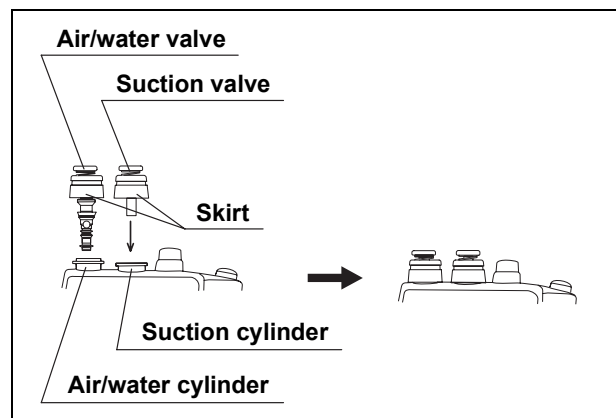

Figure 3.13

**NOTE**

The air/water valve may stick at first, but it should operate smoothly after it is depressed a few times.

## Attaching the biopsy valve

### **WARNING**

If a biopsy valve is not properly connected to the instrument channel port, it can reduce the efficacy of the endoscope's suction system and may cause patient debris to leak or spray from the endoscope.

Attach the biopsy valve to the instrument channel port of the endoscope (see Figure 3.14). Confirm that the biopsy valve fits properly.

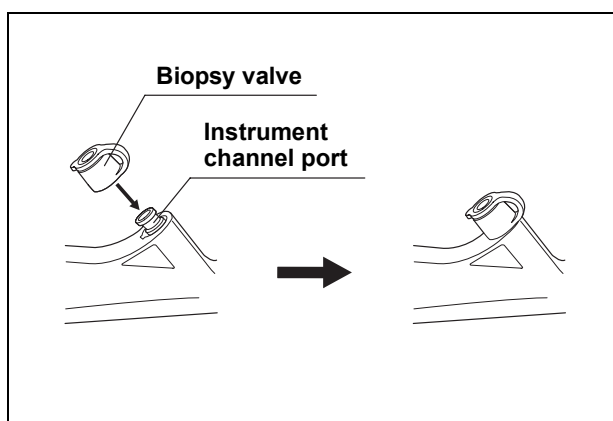

Figure 3.14

## **Attaching the distal cover**

### **WARNING**

- Never use the endoscope unless the distal cover is properly attached to the distal end. If the distal cover is not attached correctly, it may slip off or fall off the distal end during the examination. This could result in thermal injury when the endoscope is used with high-frequency endo-therapy accessories. And, continuing the examination after the distal cover has fallen off may cause patient injury by the exposed distal end of the endoscope.
- If a distal cover with cracks or pinholes is used, it could fall off during the examination and/or, it may cause thermal injury because an electric current leaks from cracks or pinholes when high-frequency cauterization treatment is performed. Never use a distal cover with cracks or pinholes but replace it with a new one.
- Do not put silicone oil, olive oil, or products containing petroleum-based lubricants (e.g. Vaseline) on the distal cover or the distal end. Silicone oil may cause deterioration of the distal cover. If the distal cover is damaged this way, it may slip off or fall off during the examination. Continuing the examination after the distal cover has fallen off may cause patient injury by the exposed distal end of the endoscope. It could also result in thermal injury when used in combination with high-frequency endo-therapy accessories.

### **CAUTION**

When attaching the distal cover, gently hold the bending section as close to the distal end as possible. Forcefully grasping other parts of the bending section can damage the mechanism of the bending section or deform its covering.

1. Keep the bending section straight and move the elevator control lever to set the forceps elevator beside the side wall area of the distal end as shown in Figure 3.15.

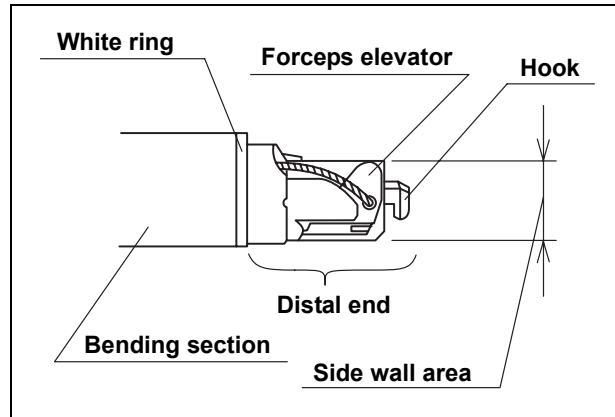

Figure 3.15

2. Gently hold the covering of the bending section as close to the distal end as possible (see Figure 3.16). Hold the top end of the distal cover with the metal insert (see Figure 3.16). Align the indication mark on the white ring with the indication mark on the distal cover.

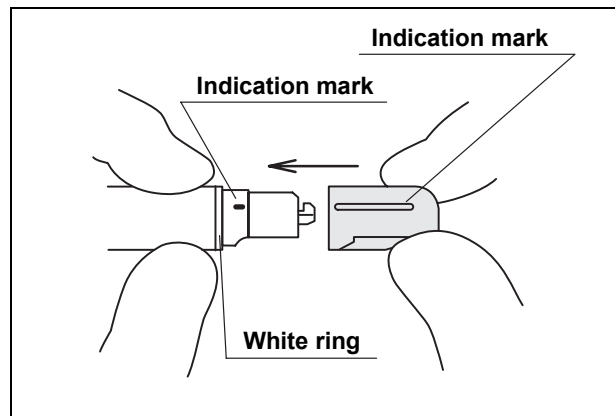

Figure 3.16

3. Push the distal cover straight onto the distal end of the endoscope until the bottom end of the distal cover contacts the end part of the white ring. Hold the bending section lightly close to the distal end and press the distal cover about 1 mm onto the distal end. When pressing the distal cover, it extends as shown in Figure 3.17.

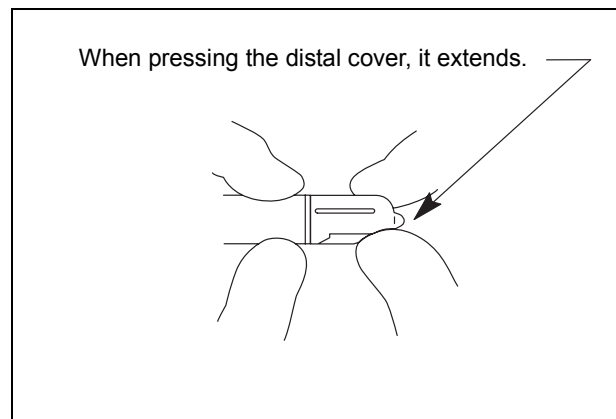

Figure 3.17

4. While maintaining the condition obtained in Step 3. (pressing the distal cover), turn the top end of the distal cover clockwise until it stops as shown in Figure 3.18.
5. After turning the distal cover, pull it lightly towards the top end of the distal cover to attach it properly to the distal end. Pulling holds the distal cover on the distal end of the endoscope completely. If the distal cover cannot be turned, it may not be pressed enough. Refer to Step 3. as shown above and repeat the Step from 3. to 5.

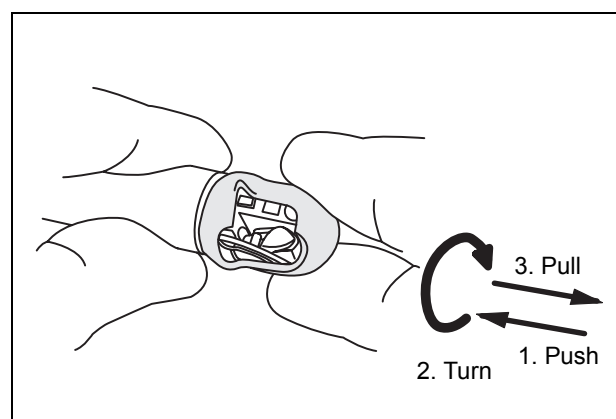

Figure 3.18

6. Confirm that there are no gaps between the distal end of the endoscope and the distal cover at the two positions indicated by the arrows in Figure 3.19.

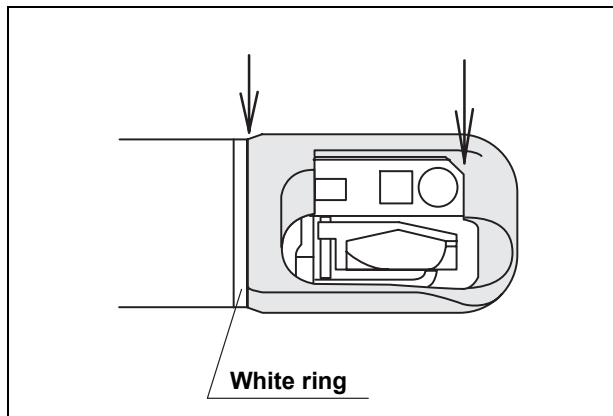

Figure 3.19

7. Confirm that the part of the distal cover indicated by an arrow and the optic surface of the endoscope are aligned as shown in Figure 3.20.

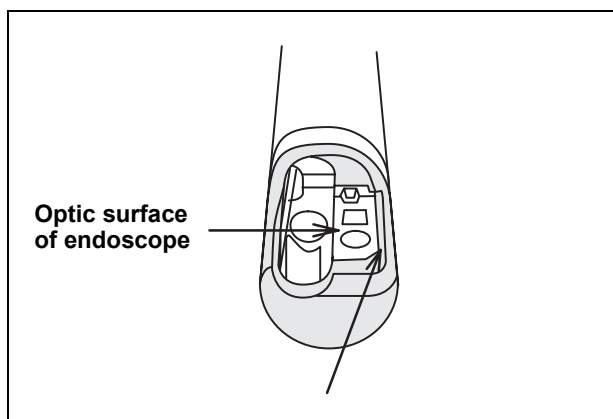

Figure 3.20

8. Hold the bottom end of the distal cover and turn it to adjust the indication mark to the straight position as shown in Figure 3.21.

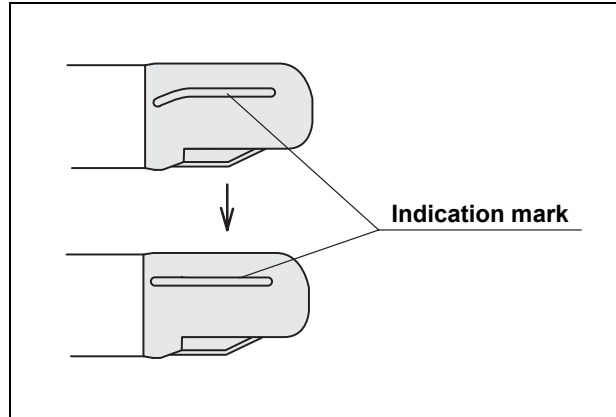

Figure 3.21

9. Confirm that the bottom end of the distal cover does not spread as shown by the arrows in Figure 3.22, and that the white ring of the distal end is not covered by the distal cover as shown in Figure 3.22. Stroke the distal cover with your fingers and pay attention that the distal cover is not put over the distal end as shown in Figure 3.23. Otherwise, the distal cover may be damaged. When Continuing the examination with the condition like mentioning above is confirmed, the distal cover may slip off the distal end during the examination. Replace the distal cover with a new one.

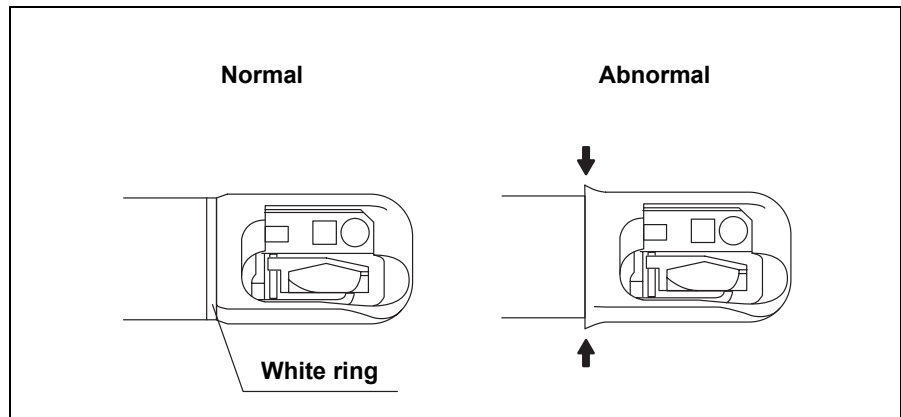

Figure 3.22

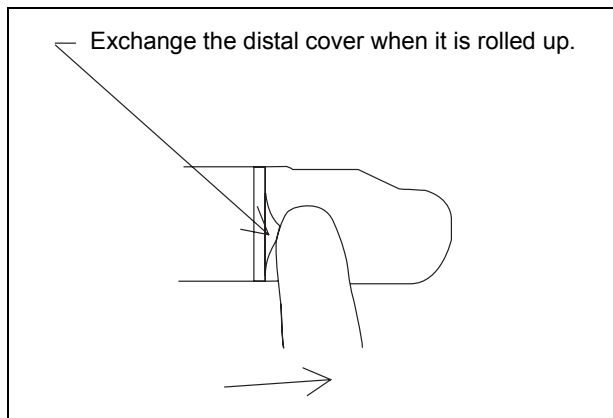

Figure 3.23

10. Pull the distal cover gently and confirm that the distal cover and the distal end of the endoscope do not separate (see Figure 3.24).
11. Twist the distal cover gently in both directions and confirm that the distal cover and the distal end of endoscope do not separate (see Figure 3.24).

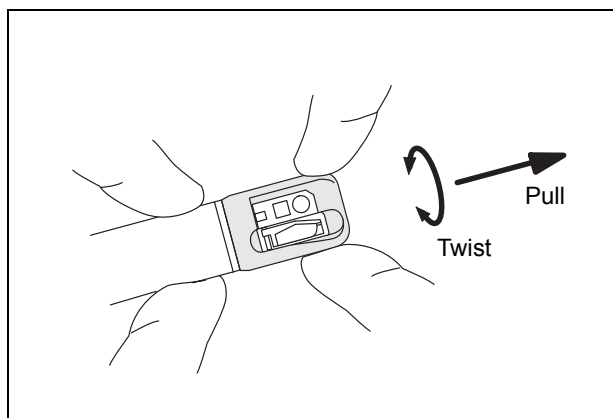

Figure 3.24

12. Confirm that the distal cover is free of cracks, wrinkles or pinholes.
13. While observing the forceps elevator at the distal end of the endoscope, move the elevator control lever slowly several times all the way in both the “◀U” direction and to the right. Confirm that the forceps elevator is not blocked by the distal cover.
14. Confirm that the distal cover cannot be seen on the endoscopic image. Even if the distal cover can be seen partly on the endoscopic image, it is not attached properly to the distal end. Detach the distal cover from the distal end. Refer to Step 1. as shown above and repeat the Step from 1. to 14.



## **3.5 Inspection and connection of ancillary equipment**

### ***Inspection of ancillary equipment***

#### **CAUTION**

- Attach the water container to the specified receptacle on the trolley or the light source. If the water container is attached anywhere else, water may drip from the water container's water supply tube, and equipment malfunction can result.
- Take care not to spill water from the water container's connection adapter when detaching the connection adapter from the endoscope. Spilled water could splash on the equipment, and it may cause equipment malfunction.

Prepare and inspect the light source, video system center, video monitor, water container, suction pump and endo-therapy accessories as described in their respective instruction manuals.

### ***Connection of the endoscope and ancillary equipment***

#### **WARNING**

Firmly connect the suction tube from the suction pump to the suction connector on the endoscope connector. If the suction tube is not attached properly, debris may drip from the tube and can present an infection-control risk, damage and/or reduce the performance.

1. If any ancillary equipment is ON, turn it OFF.
2. Insert the endoscope connector completely into the scope socket (output socket when using the CLV-U20/U40) of the light source.
3. Connect the water container's connection adapter to the air supply connector and water supply connector (see Figure 3.25).
4. Confirm that the water container's connection adapter fits properly and that the water container's connection adapter cannot be rotated.

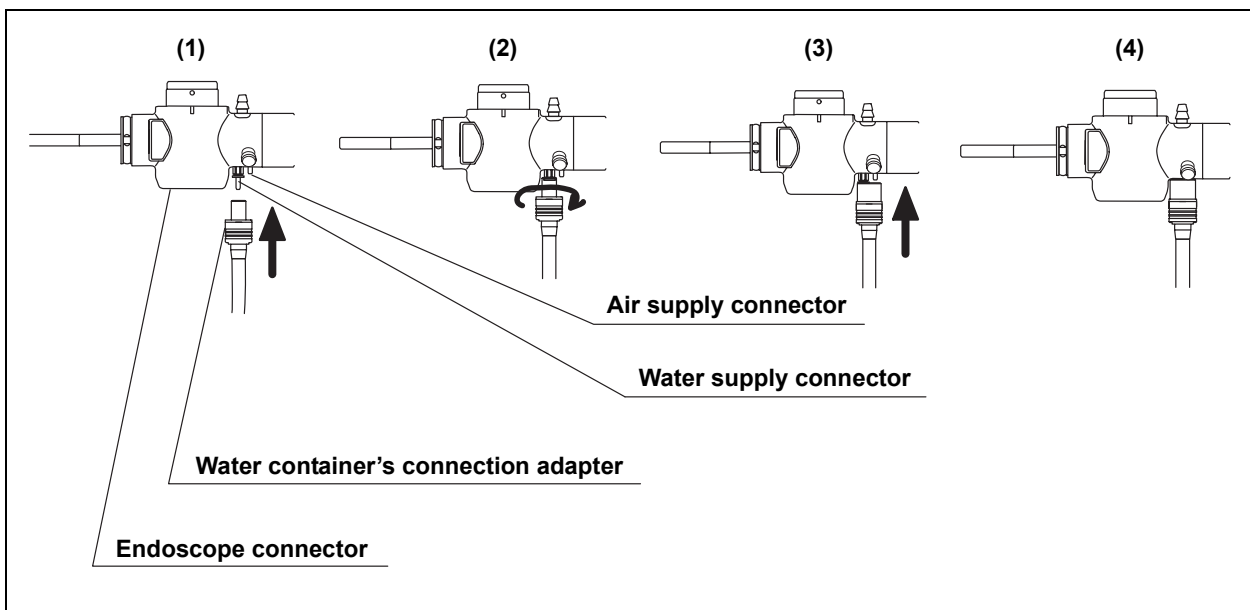

Figure 3.25

5. Align the mark on the videoscope cable EXERA or the videoscope cable 100 with mark 1 on the endoscope connector and push it in until it stops (see Figure 3.26).

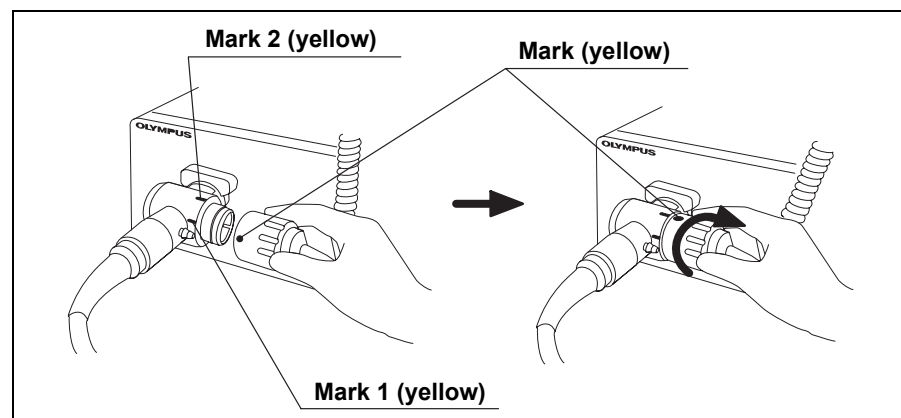

Figure 3.26

6. Turn the connector of the videoscope cable clockwise until it stops (see Figure 3.26).
7. Confirm that the mark on the videoscope cable is aligned with mark 2 on the endoscope connector.
8. Connect the suction tube from the suction pump to the suction connector on the endoscope connector (see Figure 3.27).

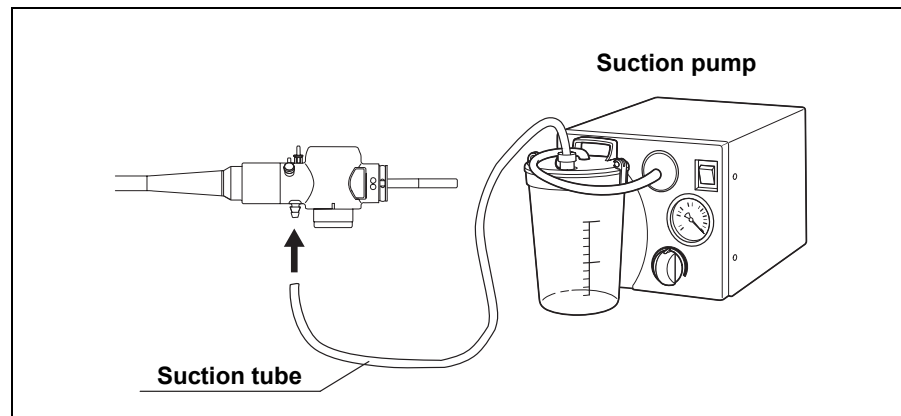

Figure 3.27

## **3.6 Inspection of the endoscopic system**

### ***Inspection of the endoscopic image***

**WARNING**

Do not stare directly at the distal end of the endoscope while the examination light is ON. Otherwise, eye injury may result.

1. Turn ON the video system center, light source and video monitor and inspect the endoscopic image as described in their respective instruction manuals.
2. Confirm the examination light output.
3. While observing the palm of your hand, confirm that the endoscopic image is free from noise, blur, fog or other irregularities.
4. Angulate the endoscope and confirm that the endoscopic image is free from momentary disappearing or other irregularities.
5. If the distal cover is visible on the endoscopic image, reattach the distal cover correctly to the distal end.

**NOTE**

If the object cannot be seen clearly, wipe the objective lens using a clean, lint-free cloth moistened with 70% ethyl or isopropyl alcohol.

### ***Inspection of remote switch***

**WARNING**

All remote control switches should be checked to work normally even when they are not expected for use. The endoscopic image may freeze or other irregularities may occur during examination and may cause patient injury, bleeding and/or perforation.

Depress every remote control switch and confirm that the specified functions work normally.

### ***Inspection of the air feeding function***

1. Set the airflow regulator on the light source to “High”, as described in the light source’s instruction manual.
2. Immerse the distal end of the insertion tube in sterile water to a depth of 10 cm and confirm that no air bubbles are emitted when the air/water valve is not operated.
3. Cover the hole in the air/water valve with your finger and confirm that air bubbles are continuously emitted from the air/water nozzle.
4. Uncover the hole in the air/water valve and confirm that no air bubbles are emitted from the air/water nozzle.

**WARNING**

If a stream of air bubbles is emitted from the air/water nozzle even though the air/water valve is not being operated and the distal end of the insertion tube is 10 cm or more below the surface of the sterile water, an irregularity in the air feeding function may be suspected. If the endoscope is used while air is continuously being fed, over-insufflation and patient injury may result.

If air bubbles are emitted from the air/water nozzle, remove and reattach the air/water valve correctly, or replace it with a new one. If this fails to stop air bubbles from being emitted, do not use the endoscope, as there may be a malfunction. Contact Olympus.

**NOTE**

When the distal end of the insertion tube is immersed less than 10 cm below the surface of the sterile water, a small amount of air bubbles may be emitted from the air/water nozzle even when the air/water valve is not operated. This does not indicate a malfunction.

### ***Inspection of the objective lens cleaning function***

**WARNING**

Use sterile water only. Non-sterile water may cause patient cross-contamination and infection.

**NOTE**

- When the air/water valve is depressed for the first time, it may take a few seconds before water is emitted.
- If the air/water valve returns to its original position slowly after water feeding, remove the air/water valve and moisten the seals with sterile water.
- During the inspection, place the distal end of the endoscope in a beaker or other container so that the floor does not get wet.

1. Keep the air/water valve's hole covered with your finger and depress the valve. Observe the endoscopic image and confirm that water flows on the entire objective lens.
2. Release the air/water valve. Observe the endoscopic image and confirm that the emission of water stops and that the valve returns smoothly to its original position.
3. While observing the endoscopic image, feed air after feeding water by covering the hole in the air/water valve with your finger. Confirm that the emitted air removes the remaining water on the objective lens and clears the endoscopic image.

## Inspection of the suction function

### **WARNING**

- If the suction valve does not operate smoothly, detach it and reattach it, or replace it with a new one. If the endoscope is used while the suction valve is not working properly, it may be impossible to stop suction, which could cause patient injury. If the reattached or replaced suction valve fails to operate smoothly, the endoscope may be malfunctioning; stop using it and contact Olympus.
- If the biopsy valve leaks, replace it with a new one. A leaking biopsy valve can reduce the efficacy of the endoscope's suction system, and may leak or spray patient debris or fluids, posing an infection-control risk.

1. Place the container of sterile water and the endoscope on the same height. For the inspection, adjust the suction pressure to the same level as it will be during the procedure.
2. Immerse the distal end of the insertion tube in sterile water with the endoscope's instrument channel port at the same height as the water level in the water container. Press the suction valve and confirm that water is continuously aspirated into the suction bottle of the suction pump.
3. Release the suction valve. Confirm that suction stops and the valve returns to its original position.
4. Depress the suction valve and aspirate water for one second. Then, release the suction valve for one second. Repeat this several times and confirm that no water leaks from the biopsy valve.
5. Remove the distal end of the endoscope from the water. Depress the suction valve and aspirate air for a few seconds to remove any water from the instrument channel.

## ***Inspection of the instrument channel and forceps elevator***

### **WARNING**

Keep your eyes away from the distal end when inserting endo-therapy accessories. Extending the endo-therapy accessory from the distal end could cause eye injury.

1. Confirm that the forceps elevator is lowered, then insert the endo-therapy accessory through the biopsy valve. Confirm that the endo-therapy accessory extends smoothly from the distal end, and that a foreign object does not come out.
2. Extend the endo-therapy accessory approximately 3 cm from the distal end. Move the elevator control lever in the “◀U” direction and confirm that the forceps elevator is raised smoothly.
3. Move the elevator control lever in the opposite direction of the “◀U” direction and confirm that the forceps elevator is lowered.
4. Confirm that the endo-therapy accessory can be withdrawn smoothly from the biopsy valve.

## Chapter 4 Operation

The operator of this instrument must be a physician or medical personnel under the supervision of a physician and must have received sufficient training in clinical endoscopic technique. This manual, therefore, does not explain or discuss clinical endoscopic procedures. It only describes basic operation and precautions related to the operation of this instrument.

### **WARNING**

- Wear personal protective equipment to guard against dangerous chemicals and potentially infectious material during operation. During operation, wear appropriate personal protective equipment, such as eye wear, face mask, moisture-resistant clothing and chemical-resistant gloves that fit properly and are long enough so that your skin is not exposed.
- The temperature of the distal end of the endoscope may exceed 41°C (106°F) and reach 50°C (122°F) due to intense endoscopic illumination. Surface temperatures over 41°C (106°F) may cause mucosal burns. Always use the minimum level of illumination, minimum time and suitable distance necessary for adequate viewing. Whenever possible, avoid close stationary viewing and do not leave the distal end of the endoscope close to the mucous membrane for a long time.
- Whenever possible, do not leave the endoscope illuminated before and/or after an examination. Continued illumination will cause the distal end of the endoscope to become hot and could cause operator and/or patient burns.
- Turn the video system center ON to operate the light source's automatic brightness function. When the video system center is OFF, it cannot operate the light source's automatic brightness function, and the light intensity is set to the maximum level. In this case, the distal end of the endoscope can become hot and could cause operator and/or patient burns.



- Never insert or withdraw the endoscope under any of the following conditions. Otherwise, patient injury, bleeding and/or perforation can result.
  - Insertion or withdrawal while the endo-therapy accessory extends from the distal end of the endoscope.
  - Insertion or withdrawal while the bending section is locked in position.
  - Insertion or withdrawal with excessive force.
  - Insertion or withdrawal while the forceps elevator is raised.
- If any of the following phenomena occur during an examination, immediately stop the examination and withdraw the endoscope from the patient as described in Section 5.2, “Withdrawal of the endoscope with an abnormality”.
  - If any abnormality is suspected with the functionality of the endoscope.
  - If the endoscopic image on the video monitor disappears or freezes unexpectedly.
  - If the angulation control knob is locked.
  - If the angulation control mechanism is not functioning properly.

Continued use of the endoscope under these conditions could result in patient injury, bleeding and/or perforation.

- If an abnormal endoscopic image/function occurs and returns to its normal condition by itself, the endoscope may have malfunctioned. Continuous use of such an endoscope may cause repetition of the abnormality, and it may not return to its normal condition. In this case, stop the examination immediately and slowly withdraw the endoscope while viewing the endoscopic image. Otherwise, patient injury, bleeding and/or perforation can result.
- If the forceps elevator cannot be lowered while using an endo-therapy accessory, stop the procedure immediately and contact Olympus on keeping the condition.
- If the distal cover should fall off the distal end during the examination, or seems to fall off, immediately stop the examination, and slowly withdraw the endoscope from the patient. Continuing the examination after the distal cover has fallen off or seems to fall off may cause patient injury by the exposed distal end of the endoscope.

**NOTE**

Set the brightness of the light source to the minimum necessary to perform the procedure safely. If the endoscope is used for a prolonged period at or near maximum light intensity, vapor like smoke may be observed in the endoscopic image. This is caused by the evaporation of organic material (remaining blood, moisture of stool and so on) due to heat generated by the light guide near the light guide lens. If this vapor continues to interfere with the examination, remove the endoscope, wipe the distal end of the endoscope with a lint-free cloth moistened with 70% ethyl or isopropyl alcohol, reinsert the endoscope and continue the examination.

## 4.1 Insertion

### *Holding and manipulating the endoscope*

The control section of the endoscope is designed to be held in the left hand. The air/water and suction valves can be operated using the left index finger. The UP/DOWN angulation control knob and the elevator control lever can be operated using the left thumb. The right hand is free to manipulate the insertion tube and the RIGHT/LEFT angulation control knob (see Figure 4.1).

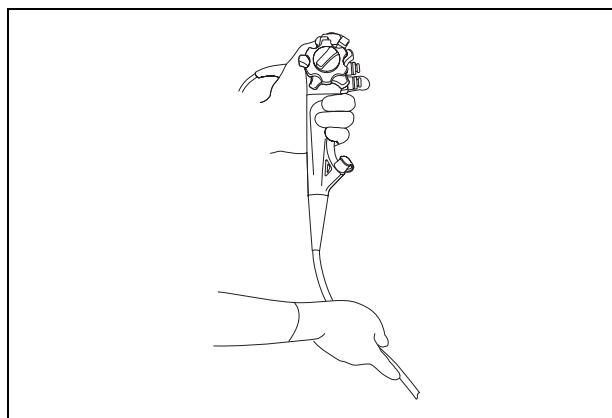

Figure 4.1

## Insertion of the endoscope

### WARNING

- Keep the elevator control lever moved all the way in the opposite direction of the “◀U” direction while inserting or withdrawing the endoscope into or from the patient. If the elevator control lever is moved all the way in the “◀U” direction and the forceps elevator is raised while inserting or withdrawing the endoscope into or from the patient, this may cause patient injury.
- Do not put silicone oil on the distal cover. Silicone oil may cause deterioration of the distal cover. A deteriorated distal cover may not be attached correctly and it may slip off or fall off the distal end during the examination. Continuing the examination after the distal cover has fallen off may cause patient injury. It could also result in thermal injury when used in combination with high-frequency endo-therapy accessories.

### CAUTION

- To prevent the patient from accidentally biting the insertion tube during an examination, it is strongly recommended that a mouthpiece be placed in the patient's mouth before inserting the endoscope.
- Do not apply olive oil or products containing petroleum-based lubricants (e.g. vaseline). These products may cause stretching and deterioration of the bending section's covering.
- Do not allow the insertion tube to be bent within a distance of 10 cm or less from the junction of the boot. Insertion tube damage can occur (see Figure 4.2).

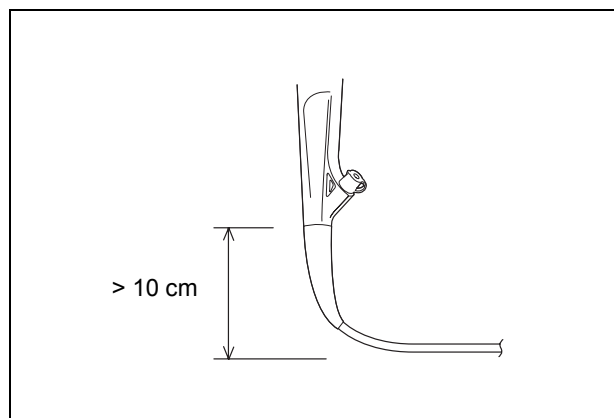

Figure 4.2

1. Move the elevator control lever in the opposite direction of the “◀U” direction until it stops.
2. If necessary, apply a medical-grade, water-soluble lubricant to the insertion tube.
3. Place the mouthpiece between the patient’s teeth or gums, with the outer flange on the outside of the patient’s mouth.
4. Insert the distal end of the endoscope through the opening of the mouthpiece, then from the mouth to the pharynx, while viewing the endoscopic image. Do not insert the insertion tube into the mouth beyond the insertion tube limit mark.

### ***Angulation of the distal end***

#### **CAUTION**

Avoid forcible or excessive angulation, as this imposes load on the wire controlling the bending section. This may cause stretching or tearing of the wire and may impair the action of the bending section.

1. Operate the angulation control knobs as necessary to guide the distal end for insertion and observation.
2. The endoscope’s angulation locks are used to hold the angulated distal end in position.

#### **NOTE**

- When passing an endo-therapy accessory through the instrument channel while the angulation is locked, the angle of the distal end may change. When it is necessary to keep the angulation stationary, hold the angulation control knobs in place with your hand.
- When operating the UP/DOWN or RIGHT/LEFT angulation lock, hold the angulation control knob stationary with your finger. If this is not done, the angulation will change.

## ***Air/water feeding and suction***

### **WARNING**

- Before using a syringe to inject liquid through the biopsy valve, detach the valve's cap from the main body. Then insert the syringe straight into the valve and inject the liquid. If the cap is not detached and/or the syringe is not inserted straight, the biopsy valve could be damaged, which could reduce the efficacy of the endoscope's suction system, and may leak or spray patient debris or fluids, posing an infection-control risk.
- If the biopsy valve is left uncapped during the procedure, debris or fluids could leak or spray from it, posing an infection-control risk. When the valve is uncapped, place a piece of sterile gauze over it to prevent leakage.

### **○ Air/water feeding**

### **WARNING**

- If the sterile water level in the water container is too low, then air, not water, will be supplied. In this case, turn OFF the airflow regulator on the light source and add sterile water till the upper bound of the specified water level in the water container.
- If air/water feeding does not stop, turn OFF the airflow regulator on the light source and attach a new air/water valve.

1. Cover the air/water valve's hole to feed air from the air/water nozzle at the distal end (see Figure 4.3).
2. Depress the air/water valve to feed water onto the objective lens (see Figure 4.3).

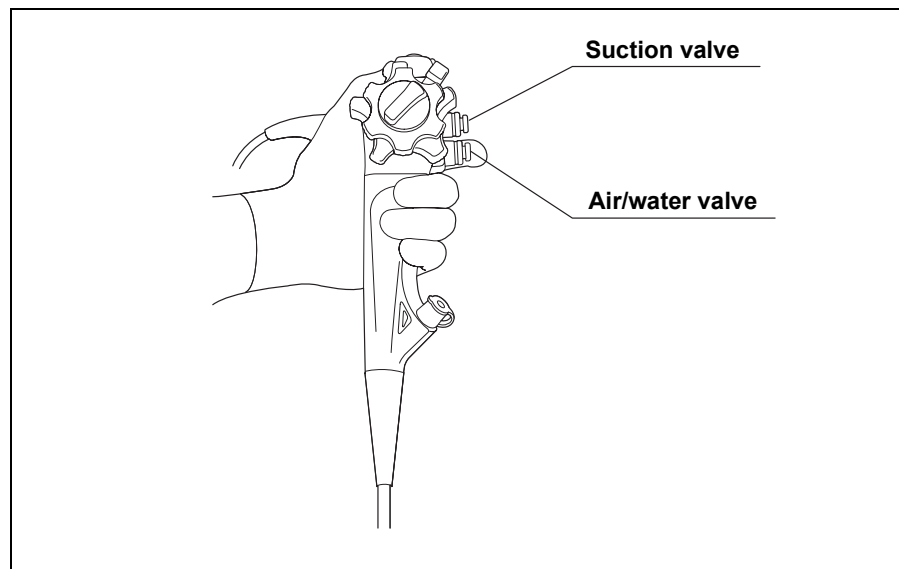

Figure 4.3

## ○ Suction

### **WARNING**

- Avoid aspirating solid matter or thick fluids; channel or valve clogging can occur. If the suction valve clogs and suction cannot be stopped, disconnect the suction tube from the suction connector on the endoscope connector. Turn the suction pump OFF, detach the suction valve and remove solid matter or thick fluids.
- When aspirating, maintain the suction pressure at the lowest level necessary to perform the procedure. Excessive suction pressure could cause aspiration of and/or injury to the mucous membrane. In addition, patient fluids could leak or spray from the biopsy valve, posing an infection-control risk.
- When aspirating, attach the cap to the main body of the biopsy valve. The uncapped biopsy valve can reduce the efficacy of the endoscope's suction system, and may leak or spray patient debris or fluids, posing an infection-control risk.

### **CAUTION**

During the procedure, take notice that the suction bottle does not fill completely. Aspirating fluids into a full bottle may cause the suction pump to malfunction.

Depress the suction valve to aspirate excess fluid or other debris obscuring the endoscopic image (see Figure 4.3).

### **NOTE**

Performing both air feeding and suction at the same time sometimes makes it easier to remove water droplets from the objective lens surface.

## ***Observation of the endoscopic image***

Refer to the light source's instruction manual for instructions on how to adjust the brightness.

## 4.2 Using endo-therapy accessories

For more information on combining the endoscope with particular endo-therapy accessories, refer to the “System chart” in the Appendix and the instruction manuals of the accessories. Refer to the accessories’ instruction manuals for operating instructions.

### **WARNING**

- When using endo-therapy accessories, keep the distance between the distal end of the endoscope and the mucous membrane greater than the endoscope’s minimum visible distance so that the endo-therapy accessory remains visible in the endoscopic image. If the distal end of the endoscope is placed closer than its own minimum visible distance, the position of the accessory cannot be seen in the endoscopic image, which could cause serious injury and/or equipment damage. The minimum visible distance depends on the type of endoscope being used. Refer to Section 2.3, “Specifications”.
- When inserting or withdrawing an endo-therapy accessory, confirm that its distal end is closed or completely retracted into the sheath. Slowly insert or withdraw the endo-therapy accessory straight into/from the slit of the biopsy valve. Otherwise, the biopsy valve may be damaged and pieces of it could fall off.
- If the insertion or withdrawal of endo-therapy accessories is difficult, straighten the bending section as much as possible without losing the endoscopic image. Inserting or withdrawing endo-therapy accessories with excessive force may damage the instrument channel or endo-therapy accessories cause some parts to fall off and/or cause patient injury.
- If the distal end of an endo-therapy accessory is not visible in the endoscopic image, do not open the distal end or extend the needle of the instrument. This could cause patient injury, bleeding, perforation and/or equipment damage.
- Do not insert endo-therapy accessories without the forceps elevator being raised. If they are inserted without the forceps elevator being raised, the accessory cannot be observed in the endoscopic image and it may cause patient injury.



- Do not insert or withdraw an endo-therapy accessory by force when the forceps elevator is raised to its maximum height. The instrument channel and/or the endo-therapy accessory may be damaged and patient injury, bleeding and/or perforation can result. If the endo-therapy accessory cannot be inserted or withdrawn, move the elevator control lever in the opposite direction of “◀U” to lower the forceps elevator and insert or withdraw the endo-therapy accessory.

**CAUTION**

- When using a biopsy forceps with a needle, confirm that the needle is not bent excessively. A bent needle could protrude from the closed cups of the biopsy forceps. Using such a biopsy forceps could damage the instrument channel and/or cause patient injury.
- When using an injector, be sure not to extend or retract the needle from the catheter of the injector until the injector is extended from the distal end of the endoscope. The needle could damage the instrument channel if extended inside the channel, or if the injector is inserted or withdrawn while the needle is extended.

***Insertion of endo-therapy accessories into the endoscope***

**WARNING**

- Do not insert endo-therapy accessories forcibly or abruptly. Otherwise, the endo-therapy accessory may extend from the distal end of the endoscope abruptly, which could cause patient injury, bleeding and/or perforation.
- When using the endo-therapy accessory with the cap of the biopsy valve detached, it is easier to insert the accessory. But, as a result, it can reduce efficacy of the endoscope's suction system, and may leak or spray patient debris or fluids, posing an infection-control risk. When not using the endo-therapy accessory, attach the cap to the main body of the biopsy valve.
- When the cap of the biopsy valve is detached, it may cause patient debris or fluids to leak or spray from the endoscope, posing an infection-control risk. When the valve is uncapped, place a piece of sterile gauze over it to prevent leakage.

- Do not let the endo-therapy accessory 'hang down' from the biopsy valve. Doing so can create a space between the accessory and the valve's slit or hole and/or damage the valve, which can reduce the efficacy of the endoscope's suction system, and may leak or spray patient debris or fluids, posing an infection-control risk.
  - Hold the part which is close to the biopsy valve of the endo-therapy accessory, and insert it straight, slowly, and little by little to the biopsy valve. Otherwise, the endo-therapy accessory and/or biopsy valve could be damaged. This can reduce the efficacy of the endoscope's suction system, and may leak or spray patient debris or fluids, posing an infection-control risk.
1. Select endo-therapy accessories compatible with the instrument from the "System chart" in the Appendix. Refer to the accessories' instruction manuals for operating instructions.
  2. Move the elevator control lever all the way in the "◀U" direction.
  3. Hold the UP/DOWN and RIGHT/LEFT angulation knobs stationary.
  4. Confirm that the tip of the endo-therapy accessory is closed or retracted into its sheath and insert the endo-therapy accessory slowly and straight into the slit of the biopsy valve.

**CAUTION**

- Do not open the tip of the endo-therapy accessory or extend the tip of the endo-therapy accessory from its sheath while the accessory is in the instrument channel. The instrument channel and/or the endo-therapy accessory may become damaged.
  - Hold the endo-therapy accessory close to the biopsy valve and insert it straight into the biopsy valve using slow, short strokes. Otherwise, the endo-therapy accessory could bend or break.
5. Hold the endo-therapy accessory approximately 4 cm from the biopsy valve and advance it slowly and straight into the biopsy valve using short strokes while observing the endoscopic image. Confirm that the tip of the endo-therapy accessory contacts the forceps elevator.
  6. Move the elevator control lever in the opposite direction of the "◀U" direction to lower the forceps elevator. Advance the endo-therapy accessory slightly and move the elevator control lever in the "◀U" direction. Confirm that the accessory appears in the endoscopic image.

7. Manipulate the elevator control lever to adjust the height of the elevator.

## **Operation of endo-therapy accessories**

Operate the endo-therapy accessory according to the directions given in its instruction manual.

## **Withdrawal of endo-therapy accessories**

### **WARNING**

- Patient debris might spray when the endo-therapy accessories are withdrawn from the biopsy valve. Apply gauze to the biopsy valve to prevent patient debris to spray.
- Do not withdraw the endo-therapy accessory if the tip is open or extended from its sheath; patient injury, bleeding, perforation and/or instrument damage may occur.
- Withdraw the endo-therapy accessory slowly and straight out of the biopsy valve. Otherwise, the valve's slit and/or hole could be damaged. This can reduce the efficacy of the endoscope's suction system, and may leak or spray patient debris or fluids, posing an infection-control risk.
- If the endo-therapy accessory cannot be withdrawn from the endoscope, close the endo-therapy accessory and/or retract it into its sheath, then carefully withdraw both the endoscope and the endo-therapy accessory together under endoscopic observation. Take care not to cause tissue trauma.

1. Close the tip of the endo-therapy accessory and/or retract it into its sheath.
2. While lowering the forceps elevator gradually, slowly withdraw the endo-therapy accessory.

## **Fixing the guidewire**

When a wire guided type endo-therapy accessory (endo-therapy accessory which has a lumen for a guidewire) and a guidewire are used, and only the wire guided type endo-therapy accessories are exchanged while detaining the guidewire in the desired position, the guidewire can be fixed at the distal end of the endoscope supportly. In other words, this function can be used when a wire guided type endo-therapy accessory is withdrawn from the guidewire detained in the biliary/pancreatic duct and inserted along the guidewire detained in the biliary/pancreatic duct. When fixing the guidewire please follow the warnings below.

**WARNING**

- Do not use a guidewire when its outer surface is damaged, ripped or torn. Leakage current can be discharged from damaged parts of the guidewire, which could cause burns to the patient, operator and/or assistant, damage the endoscope, equipment and/or endo-therapy accessory.
- Insert and withdraw a wire guided type endo-therapy accessory slowly and carefully when the guidewire is locked in the guidewire-locking groove at the distal end of endoscope. If the endo-therapy accessory is withdrawn or inserted along the guidewire with excessive force or rapidly while the guidewire is locked, the following phenomena may occur. Also do not move the guidewire while it is locked at the distal end of the endoscope. Otherwise, the following phenomena may occur.
  - The guidewire comes off the guidewire-locking groove and cannot be fixed at the distal end of the endoscope.
  - The guidewire goes deep inside the patient's body and patient injury, bleeding and /or perforation can result.
  - The outer surface of the guidewire becomes damaged, ripped or torn, and pieces of the outer surface might fall into the patient's body.
  - The outer surface of the guidewire is damaged, ripped or torn, and leakage current can be discharged from damaged parts of the guidewire, which could cause burns to the patient, operator and/or assistant, damage the endoscope, equipment and/or endo-therapy accessory.
- Observe the endoscopic images to confirm that the guidewire is locked at the distal end of the endoscope when withdrawing or inserting a wire guided type endo-therapy accessory. If the guidewire is not locked properly, patient injury, bleeding and/or perforation can result.
- Observe the X-ray images and slowly insert or withdraw the wire guided type endo-therapy accessory while the guidewire is sticking out of it. Otherwise, patient injury, bleeding and/or perforation can result.

- Do not withdraw the endoscope if the guidewire is stuck in the guidewire-locking groove at the distal end. Patient injury, bleeding and/or perforation can result. In this case, insert a wire guided type endo-therapy accessory over the guidewire from its proximal end, while observing the endoscopic images to confirm that the guidewire does not penetrate patient tissue. When the endo-therapy accessory passes through the groove, it removes the guidewire from the groove.
- The maximum angle of the forceps elevator is slightly increased compared with conventional duodenoendoscopes, due to the need to fix the guidewire at the distal end. Therefore, endo-therapy accessories can be raised higher than with other conventional duodenoendoscopes. Closely observe the endoscopic image when using an endo-therapy accessory with this endoscope, particularly while performing papillotomy. Do not manipulate the elevator control lever and/or endo-therapy accessory without closely viewing the endoscopic image, as patient injury, bleeding and/or perforation can result.

**NOTE**

- The assistant function of the fixation works most effectively with guidewires with a diameter of  $\varnothing$  0.89 mm (0.035 inch).
- The assistant function of the fixation may not work effectively in the following conditions.
  - If the elevator control lever is not held stationary.
  - If the proximal ends of the wire guided type endo-therapy accessory and the guidewire are not straight.
  - If the contrast media in the guidewire lumen of the endo-therapy accessory is not washed with physiology salt solution.
  - If the wire guided type endo-therapy accessory is kinked, deformed or damaged.
  - If the combination of the guidewire and the wire guided type endo-therapy is incorrect.
  - If an attempt is made to fix more than one guidewire simultaneously.
  - If the position of the distal end of the endoscope and the papilla is not appropriate for the assistant function of the guidewire fixation (see NOTE on page 59).

When the assistant function of the guidewire fixation does not work effectively, using a guidewire with a length of less than 4.5 m may make it difficult to exchange the wire guided type endo-therapy accessories. Prepare the guidewire with a length of 4.5 m or more.

**NOTE**

Using a guidewire with a length of 4.5 m or more, wire guided type endo-therapy accessories can be exchanged without using the assistant function of the guidewire fixation.

**○ Withdrawal of wire guided type endo-therapy accessories**

1. Insert the guidewire to the proximal end of the guidewire-type endo-therapy accessory and advance the guidewire until it reaches the desired position while observing the endoscopic image and X-ray images.
2. When the forceps elevator is lowered, an operator and an assistant work together to pull the end of the endo-therapy accessory into the endoscope while observing the endoscopic image and X-ray images.
3. When only the guidewire is extended from the endoscope's distal end, slowly move the elevator control lever all the way in "◀U" direction until it stops.
4. The guidewire is fixed in the guidewire-locking groove on the forceps elevator at the endoscope's distal end (see Figure 4.4).

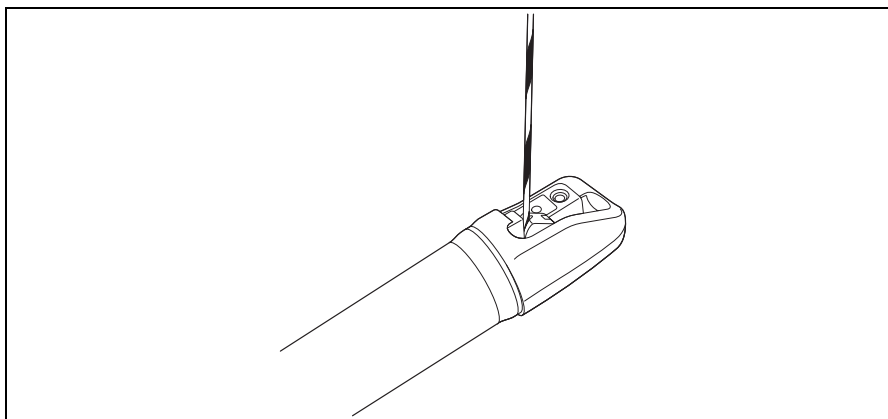

Figure 4.4

**NOTE**

The stiff part of the guidewire is fixed at the guidewire-locking groove more effectively.

5. Withdraw the endo-therapy accessory slowly while holding the elevator control lever stationary so that the elevator and the guidewire do not move forward to the “◀U” direction. Observe the endoscopic and X-ray images while withdrawing the accessory.

**NOTE**

The assistant function of the guidewire fixation may not function effectively due to the position of the distal end of the endoscope and the papilla, because the guidewire comes off the guidewire-locking groove of the forceps elevator by being bent the guidewire. In this case, change the position of the distal end (see Figure 4.5).

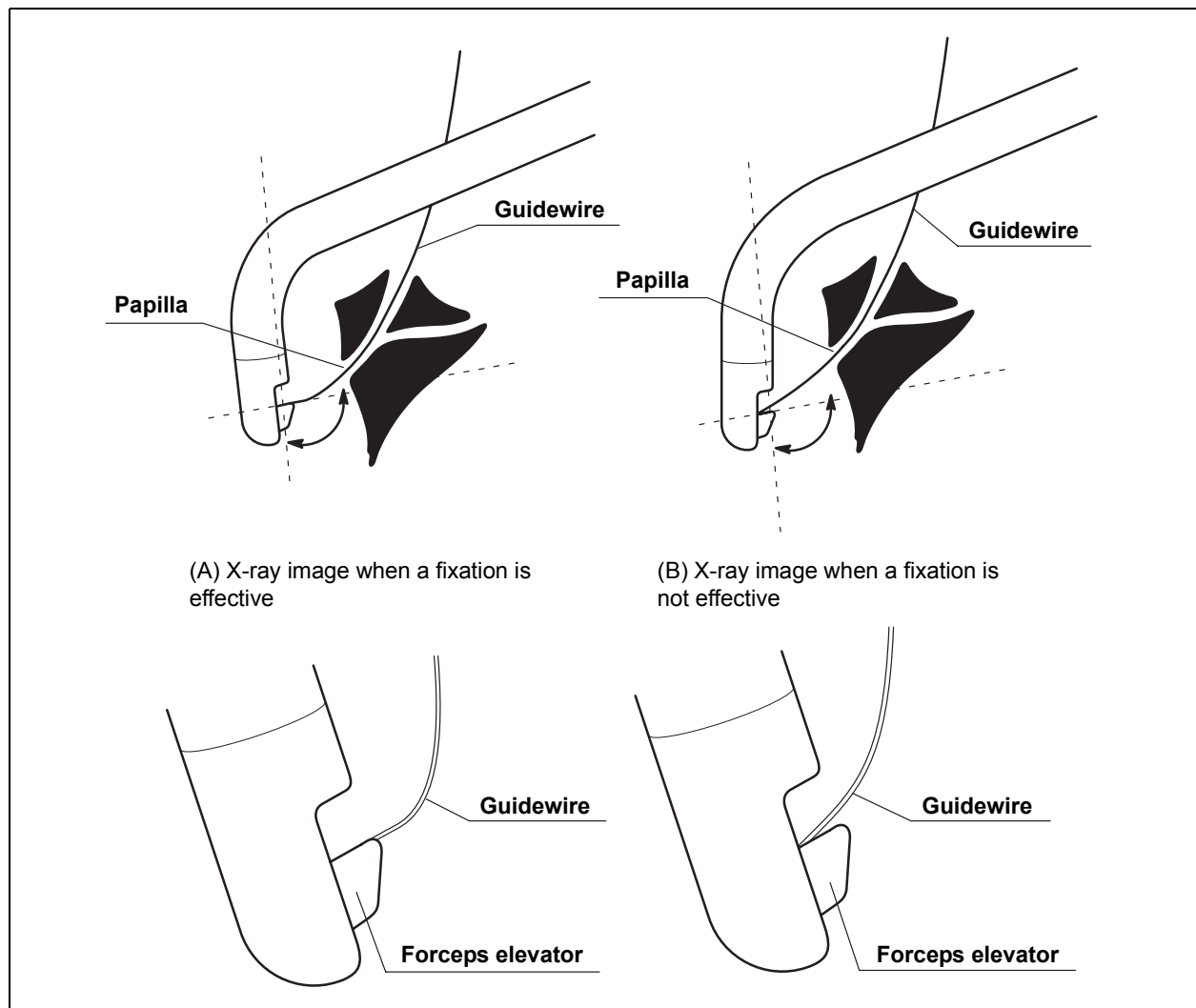

Figure 4.5

## ○ Insertion of wire guided type endo-therapy accessories

1. Move the elevator control lever all the way in the “◀U” direction slowly until it stops while only the guidewire is extended from the endoscope’s distal end.
2. Hold the elevator control lever stationary that it can no longer move forward in the “◀U” direction. Then insert a wire guided type endo-therapy accessory slowly from the proximal end of the guidewire while observing the endoscopic image and X-ray images.
3. When the tip of the wire guided type endo-therapy accessory comes in contact with the forceps elevator, move the elevator control lever in the opposite direction of the “◀U” direction to lower the forceps elevator while observing the endoscopic images.
4. While observing endoscopic images and X-ray images, an operator and their assistant should work together to insert the endo-therapy accessory carefully without moving the guidewire from the desired position.

## **High frequency cauterization**

### **WARNING**

- If the intestines contain a flammable gas, replace it with air or a non-flammable gas such as CO<sub>2</sub> before performing high frequency cauterization treatment. Otherwise, fire or explosion could result.
- Not all parts of the endoscope are electrically insulated. When applying high frequency current, there is a danger of unintentional diathermy burns. Always wear electrically insulating chemical-resistant gloves.
- Never emit high frequency current before confirming that the distal end of the high frequency endo-therapy accessory is in the endoscopic field of view. Also confirm that the electrode section and the mucous membrane in the vicinity of the target area are at an enough distance from the distal end of the endoscope. If the high frequency current is emitted while the distal end of the endo-therapy accessory is not visible or too close to the distal end of the endoscope, patient injury, bleeding and/or perforation as well as equipment damage can result.



- If the distal cover should fall off or slip off the distal end during the examination, immediately stop the examination, and slowly withdraw the endoscope from the patient. If the distal cover falls off or slips off the distal end, do not perform high frequency cauterization treatment. This could result in cauterization of body cavity areas outside the endoscopic field of view.

Prepare, inspect and connect the electrosurgical unit and electrosurgical accessories as described in their instruction manuals.

**NOTE**

The application of high frequency current may interfere with the endoscopic image. This is normal and does not indicate a malfunction.

## **4.3 Withdrawal of the endoscope**

**WARNING**

If blood unexpectedly adheres to the surface of the insertion tube of the withdrawn endoscope, check the conditions of the patient carefully.

1. Aspirate accumulated air, blood, mucus or other debris by depressing the suction valve.
2. Turn the UP/DOWN and RIGHT/LEFT angulation locks to the “F ►” direction to release them.
3. Carefully withdraw the endoscope while observing the endoscopic image.
4. Remove the mouthpiece from the patient’s mouth.

## 4.4 Transportation of the endoscope

### *Transporting within the hospital*

When carrying the endoscope by hand, loop the universal cord, hold the endoscope connector together with the control section in one hand and hold the distal end of the insertion tube securely, but gently without squeezing, in the other hand (see Figure 4.6).

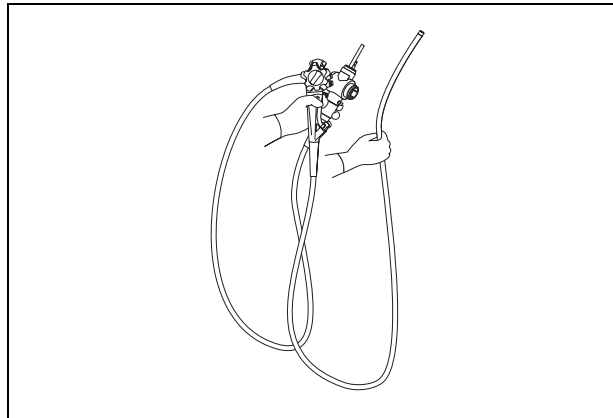

Figure 4.6

### *Transporting outside the hospital*

Transport the endoscope in the carrying case.

#### **WARNING**

Always clean, disinfect or sterilize the endoscope after removing it from the carrying case. If the endoscope is not cleaned, disinfected or sterilized, the patient might be infected.

#### **CAUTION**

- The carrying case cannot be cleaned, disinfected or sterilized. Clean and disinfect or sterilize the endoscope before placing it in the carrying case.
- Do not attach the water-resistant cap when transporting the endoscope, to avoid damage to the endoscope caused by changes in air pressure.
- When putting the endoscope in the carrying case, do not touch the forceps elevator or the elevator wire at the distal end with your hand. This could result in damage.

# **Chapter 5 Troubleshooting**

If the endoscope is visibly damaged, does not function as expected or is found to have irregularities during the inspection described in Chapter 3, "Preparation and Inspection", do not use the endoscope. Contact Olympus.

Some problems that appear to have irregularities may be correctable by referring to Section 5.1, "Troubleshooting guide". If the problem cannot be resolved by the described remedial action, stop using the endoscope and contact Olympus.

Olympus does not repair accessory parts. If an accessory part becomes damaged, contact Olympus to purchase a replacement.

## **WARNING**

- Never use the endoscope on a patient if an abnormality is suspected. Damage or irregularity in the instrument may compromise patient or user safety and may result in more severe equipment damage.
- If any parts of the endoscope fall off inside the patient body due to equipment damage or failure, stop using the endoscope immediately and retrieve the parts in an appropriate way.

If any abnormality in the function of the endoscope and/or endoscopic image is suspected during use, stop the examination immediately and carefully withdraw the endoscope from the patient as described in Section 5.2, "Withdrawal of the endoscope with an abnormality".

## **5.1 Troubleshooting guide**

The following table shows the possible causes of and countermeasures against troubles that may occur due to equipment setting errors or deterioration of consumables.

Troubles or failures due to other causes than those listed below should be serviced. As repair performed by persons who are not qualified by Olympus could cause patient or user injury and/or equipment damage, be sure to contact Olympus for repair following the instructions given in Section 5.3, "Returning the endoscope for repair".

## Endoscope functions

### ○ Angulation

Irregularity description	Possible cause	Solution
Resistance is encountered when rotating angulation control knob(s).	The angulation lock(s) is (are) engaged.	Rotate angulation lock(s) in the “F ▶” direction.

### ○ Air/water feeding

Irregularity description	Possible cause	Solution
No air feeding.	The air pump is not operating.	Press the LOW, MED or HIGH button on the light source as described in the light source's instruction manual.
	The air/water valve is damaged.	Replace it with a new one.
No water feeding.	The air pump is not operating.	Press the LOW, MED or HIGH button on the light source as described in the light source's instruction manual.
	There is no sterile water in the water container.	Add sterile water to fill the container to the specified level.
	The air/water valve is damaged.	Replace it with a new one.
The air/water valve is sticky.	The air/water valve is dirty.	Remove the air/water valve. Reprocess the air/water valve and then attach it again.
	The air/water valve is damaged.	Replace it with a new one.
The air/water valve cannot be attached.	An incorrect air/water valve is used.	Use a correct air/water valve.
	The air/water valve is damaged.	Replace it with a new one.

## ○ Suction

Irregularity description	Possible cause	Solution
The suction is absent or insufficient.	The biopsy valve is not attached properly.	Attach it correctly.
	The biopsy valve is damaged.	Replace it with a new one.
	The suction pump is not set properly.	Adjust the suction pump's setting as described in its instruction manual.
	The suction valve is damaged.	Replace it with a new one.
The suction valve is sticky.	The suction valve is dirty.	Remove the suction valve. Reprocess the suction valve and attach it again.
	The suction valve is damaged.	Replace it with a new one.
The suction valve cannot be attached.	The suction valve is damaged.	Replace it with a new one.
	An incorrect suction valve is used.	Use a correct suction valve.
Liquid leaks out from the biopsy valve.	The biopsy valve is damaged.	Replace it with a new one.
	The biopsy valve is not attached properly.	Attach it correctly.

## ○ Image quality or brightness

Irregularity description	Possible cause	Solution
There is no video image.	Not all power switches are ON.	Turn ON all the power switches.
An image is not clear.	The objective lens is dirty.	Feed water to remove mucus, etc.
An image is excessively dark or bright.	The light source is not set properly.	Adjust the light source's setting as described in its instruction manual.
An image is abnormal.	An incompatible video system center is being used.	Select a compatible video system center.
	An incompatible light source is being used.	Select a compatible light source.

## ○ Endo-therapy accessories

Irregularity description	Possible cause	Solution
Endo-therapy accessory does not pass through the instrument channel smoothly.	An incompatible endo-therapy accessory is being used.	Refer to the "System chart" in the Appendix and select a compatible endo-therapy accessory. Confirm that the color code on the endo-therapy accessory matches that on the endoscope.
The elevator control lever does not operate smoothly.	The elevator wire or the elevator wire channel is dirty.	Clean and disinfect or sterilize the elevator wire channel as described in the "REPROCESSING MANUAL" whose cover lists the model of your endoscope.
Guidewire cannot be fixed at all.	Guidewire is not fixed at its stiff part.	Fix the guidewire at its stiff part.
	Guidewire with a diameter other than $\varnothing$ 0.89 mm is used.	Select a guidewire whose diameter is $\varnothing$ 0.89 mm.
	Guidewire locking groove is dirty.	Clean and disinfect or sterilize the guidewire locking groove as described in the "REPROCESSING MANUAL" whose cover lists the model of your endoscope.
	Contrast media is congealed in the guidewire lumen of the endo-therapy accessory.	Clean the lumen in the endo-therapy accessory and then insert/withdraw it.

### ○ Distal cover

Irregularity description	Possible cause	Solution
The distal cover cannot be attached.	An improper distal cover (not MAJ-311) is used.	Use proper distal cover (MAJ-311).

### ○ Others

Irregularity description	Possible cause	Solution
The remote switch does not work.	The wrong remote switch is operated.	Operate the correct remote switch.
	The remote switch function has been set improperly.	Set the remote switch function correctly as described in the video system center's instruction manual.

## 5.2 *Withdrawal of the endoscope with an abnormality*

If an abnormality occurs while the endoscope is in use, take a proper measure as described in either “When the endoscopic image appears on the monitor” or “When the endoscopic image does not appear on the monitor or the frozen image cannot be restored” below. After withdrawal, return the endoscope for repair as described in Section 5.3, “Returning the endoscope for repair”.

### **WARNING**

If the endoscope or endo-therapy accessory cannot be withdrawn from the patient smoothly, do not attempt to forcibly withdraw it. If any irregularities are suspected, immediately contact Olympus. Forcibly withdrawing the endoscope or endo-therapy accessory may cause patient injury, bleeding and/or perforation.

### *When the endoscopic image appears on the monitor*

1. Turn OFF all equipment except the video system center, light source and monitor.
2. When using the image magnification function of the video system center, release the function.

3. When using an endo-therapy accessory, close the tip of the endo-therapy accessory and/or retract into its sheath. Withdraw the endo-therapy accessory slowly while lowering the forceps elevator gradually.
4. Aspirate accumulated air, blood, mucus or other debris by depressing the suction valve.
5. Turn the UP/DOWN and RIGHT/LEFT angulation locks in the “F▶” direction to release them.
6. Carefully withdraw the endoscope while observing the endoscopic image.
7. Remove the mouthpiece from the patient’s mouth.

***When the endoscopic image does not appear on the monitor or the frozen image cannot be restored***

1. Turn OFF all equipment except the video system center, the light source and the monitor.
2. Turn the video system center and light source OFF and then ON again. If the endoscopic image appears or the frozen image restored, follow the procedure of Step 2. and below in “When the endoscopic image appears on the monitor” on page 67.  
When the endoscopic image still does not appear or the frozen image cannot be restored, perform the following steps.
3. Turn OFF the video system center, the light source and the monitor.
4. When using an endo-therapy accessory, close the tip of the endo-therapy accessory and/or retract into its sheath. Withdraw the endo-therapy accessory slowly while lowering the forceps elevator gradually.
5. Turn the UP/DOWN and RIGHT/LEFT angulation locks in the “F▶” direction to release them.
6. Turn the UP/DOWN and RIGHT/LEFT angulation control knobs to their respective neutral positions (see Figure 3.4). Release the angulation control knobs and carefully withdraw the endoscope.
7. Remove the mouthpiece from the patient’s mouth.



## **5.3 Returning the endoscope for repair**

### **WARNING**

Thoroughly clean and high-level disinfect or sterilize the endoscope before returning it for repair. Improperly reprocessed equipment presents an infection-control risk to each person who handles the endoscope within the hospital or at Olympus.

Before returning the endoscope for repair, contact Olympus. With the endoscope, include a description of the malfunction or damage and the name and telephone number of the individual at your location who is most familiar with the problem. Also include a repair purchase order.

When returning the endoscope for repair, follow the instructions given in "Transporting outside the hospital" on page 62.



# ***Appendix***

## ***System chart***

The recommended combinations of equipment and accessories that can be used with this instrument are listed below. Some items may not be available in some areas. New products released after the introduction of this instrument may also be compatible for use in combination with this instrument. For further details, contact Olympus.

**WARNING**

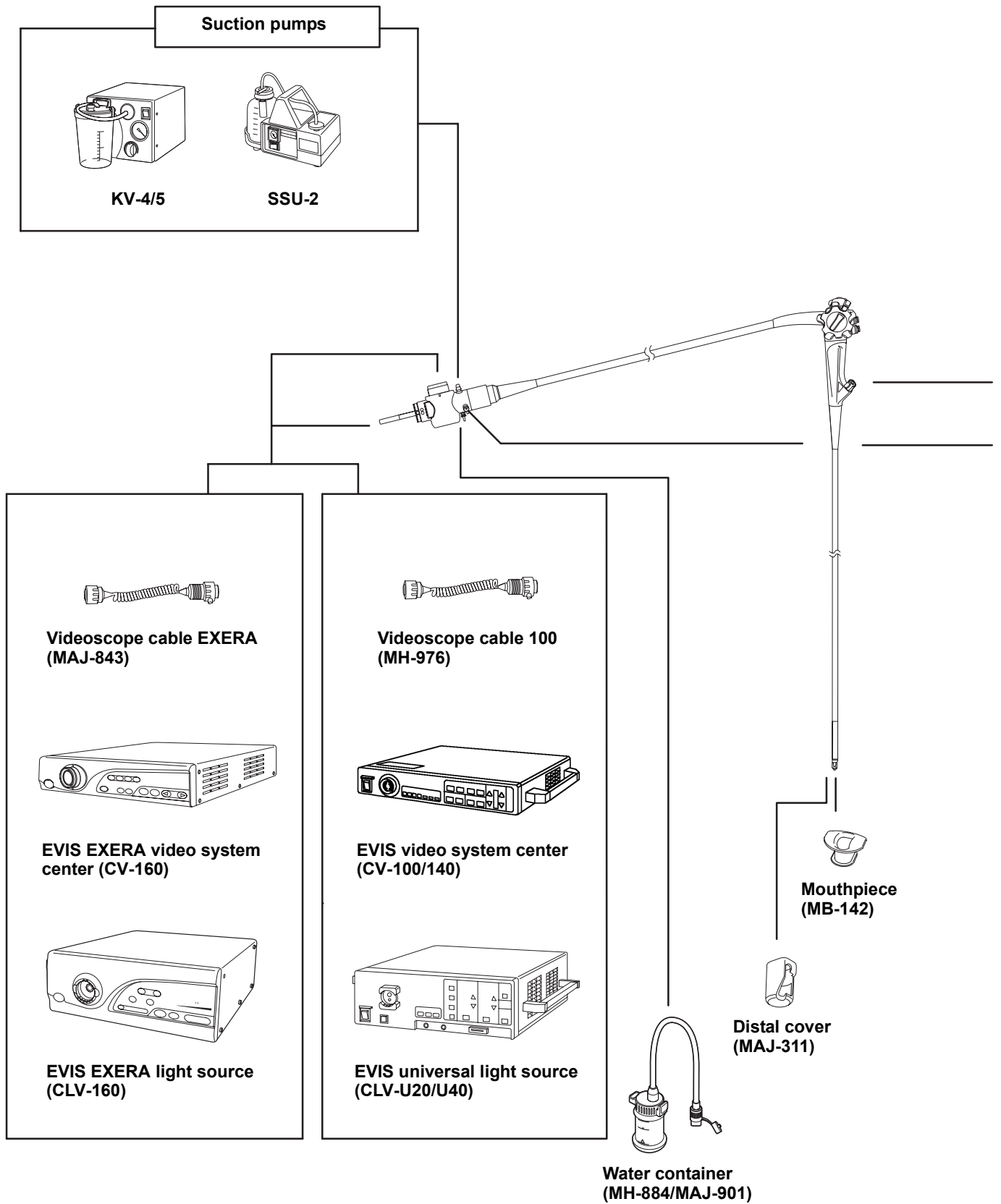

If combinations of equipment other than those shown below are used, the full responsibility is assumed by the medical treatment facility.

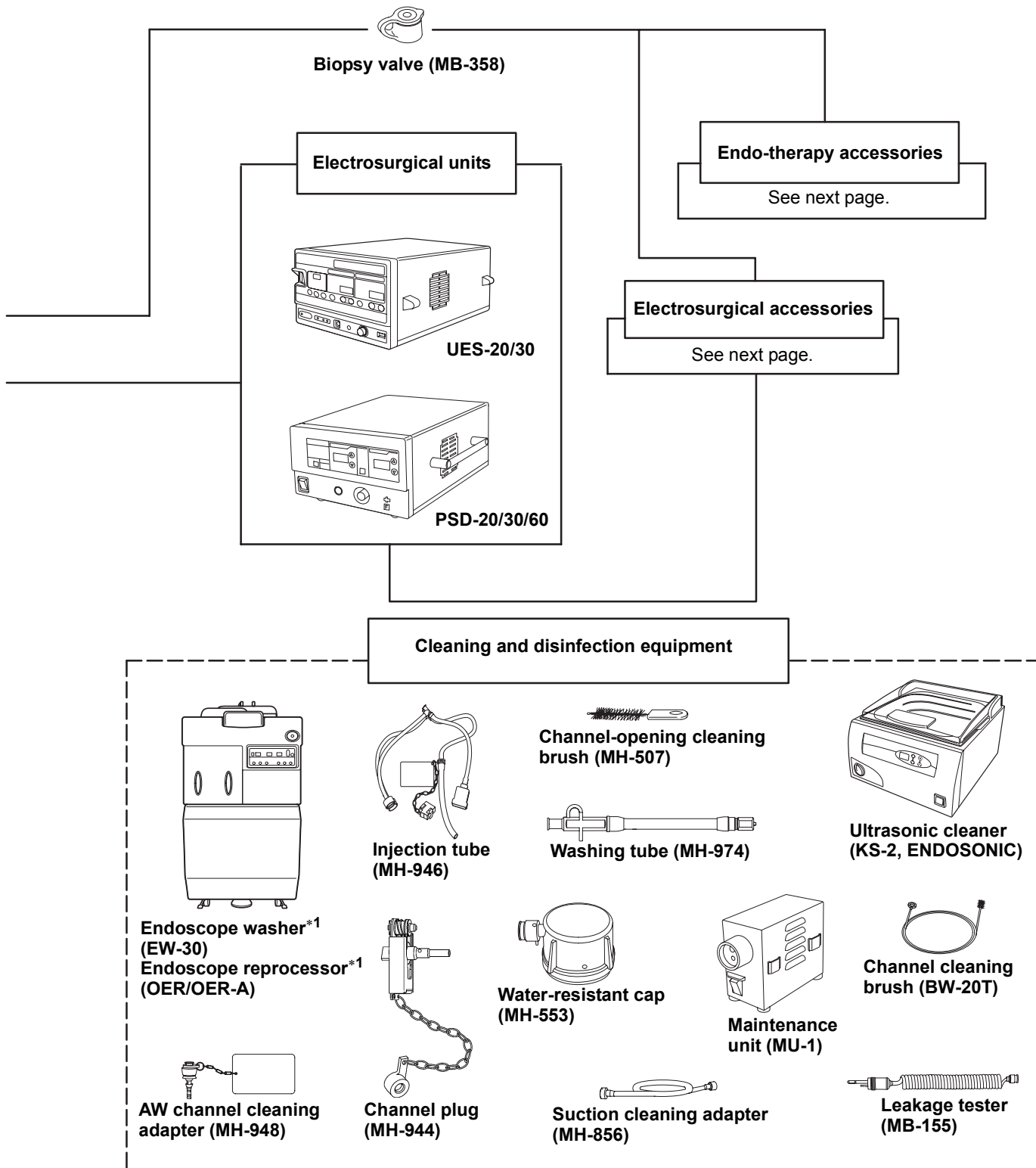



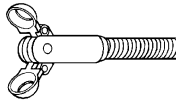
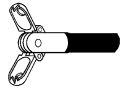

\*1 These products may not be available in some areas.



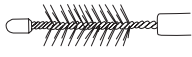
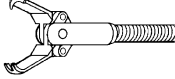
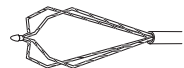
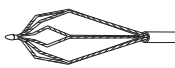

○ Endo-therapy accessories

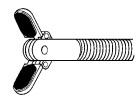
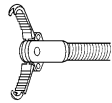
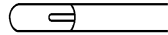

Endoscope	BIOPSY FORCEPS			
	Fenestrated type	Rat tooth	Alligator type	Alligator type with rat tooth
				
TJF-160VR	FB-19N-1/26N-1	FB-39Q-1/40Q-1	FB-45Q-1	FB-46Q-1

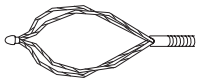



Endoscope	Disposable cytology brush	GRASPING FORCEPS		
		Rat tooth	Basket type	Flower basket type
				
TJF-160VR	BC-23Q/24Q	FG-14P-1	FG-18Q-1/22Q-1/ 23Q-1	FG-301Q

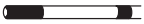
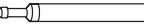



Endoscope	DISPOSABLE GRASPING FORCEPS	
	Flower basket type	Basket type
		
TJF-160VR	FG-401Q	FG-402Q/403Q

Endoscope	GRASPING FORCEPS	ROTATABLE GRASPING FORCEPS	HEAT PROBE
	Rubber tips (Non-latex)	Rat tooth with alligator type	
			
TJF-160VR	FG-20P-1	FG-44NR-1	CD-11Z/21Z/110U/ 120U

Endoscope	MECHANICAL LITHOTRIPTOR		DISPOSABLE MECHANICAL LITHOTRIPTOR	CANNULA
	Basket type	Slide type	Slide type	Standard type
				
TJF-160VR	BML-1Q-1/2Q-1	BML-3Q-1/4Q-1	BML-201Q/202Q/ 203Q/204Q	PR-104Q-1/ 106Q-1/304Q*1, *2





Endoscope	CANNULA			
	Indwelling type	Metal-tip with stylet	Metal-tip type	Hard
				
TJF-160VR	PR-5Z-1*1	PR-7Q-1	PR-11Q-1/128Q-1*1	PR-108Q-1



Endoscope	CANNULA			
	Slitted	Short tapered	Long tapered	With ball tip
				
TJF-160VR	PR-126Q-1*1/ 326Q*1, *2	PR-109Q-1/ 113Q-1*1/309Q*2/ 313Q*1, *2	PR-110Q-1/ 112Q-1*1/310Q*2	PR-24Q-1*1





Endoscope	CANNULA		DISPOSABLE CANNULA	
	Lateral openings	Metal tip	Standard type	Metal-tip type
				
TJF-160VR	PR-130Q	PR-131Q/132Q	PR-216Q/416Q*1, *2	PR-229Q*1



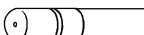

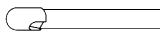
\*1 These accessories shows the endo-therapy applicable to guidewire of  $\varnothing$  0.89 mm (0.035 inch) diameter.

\*2 These accessories may not be available in some area.

Endoscope	DISPOSABLE CANNULA			
	Stiff type	Slitted	Short tapered	Long tapered
				
TJF-160VR	PR-217Q	PR-227Q*1/ 427Q*1, *2	PR-214Q*1/218Q/ 225Q*1/414Q*1, *2/ 418Q*2	PR-220Q/420Q*2

Endoscope	DISPOSABLE CANNULA		DISPOSABLE BENDING CANNULA	WASHING PIPE
	Ball tip	Metal tip		Spray type
				
TJF-160VR	PR-23Q*1	PR-231Q/232Q	PR-233Q*1	PW-6P-1



Endoscope	WASHING PIPE	BILIARY DRAINAGE TUBE		
	Retro jet	7 Fr., 10 Fr., 12 Fr.	7 Fr.	7 Fr., 8.5 Fr., 10 Fr., 12 Fr.
				
TJF-160VR	PW-8Q-1	PBD-3Z-1*1/4Z-1*1/ 6Z-1*1	PBD-7Z-1*1	PBD-210R*1/210Z*1



Endoscope	BILIARY DRAINAGE TUBE			NASAL BILIARY DRAINAGE TUBE (7 Fr., 5 Fr.)
	7 Fr., 8.5 Fr., 10 Fr., 12 Fr.	10 Fr.	10 Fr.	Short α type
				
TJF-160VR	PBD-211R*1/211Z*1	PBD-421R*1/421Z*1	PBD-422R*1/422Z*1	PBD-20Z*1/24Z*1

\*1 These accessories shows the endo-therapy applicable to guidewire of ø 0.89 mm (0.035 inch) diameter.

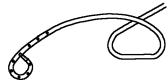
\*2 These accessories may not be available in some area.

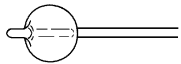

Endoscope	NASAL BILIARY DRAINAGE TUBE (7 Fr., 5 Fr.)			BALLOON CATHETER
	Pigtail type	$\alpha$ type	Reverse $\alpha$ type	
				
TJF-160VR	PBD-21Z*1/25Z*1	PBD-22Z*1/26Z*1	PBD-23Z*1/27Z*1	B7-2Q*1/2LA*1 B5-2Q/2LA B-230Q-A/B*1

Endoscope	MEASURING DEVICE	GUIDE CATHETER
	Straight type	
		
TJF-160VR	M1-2U	MD-984

\*1 These accessories shows the endo-therapy applicable to guidewire of  $\varnothing$  0.89 mm (0.035 inch) diameter.

○ Electrosurgical accessories





Endoscope	ELECTROSURGICAL SNARE		DISPOSABLE HOT BIOPSY FORCEPS
	Crescent	Hexagonal	
	TJF-160VR	SD-7P-1	SD-8P-1



Endoscope	PAPILLOTOMY KNIFE			PAPILLOTOMY KNIFE WITH SIDE HOLE
	Pull type	Push type	Push-pull type	Pull type
	TJF-160VR	KD-4Q-1/5Q-1/16Q-1 to 26Q-1/30Q-1	KD-27Q-1	KD-6Q-1/28Q-1 /29Q-1



Endoscope	PAPILLOTOMY KNIFE (WIRE GUIDED TYPE)	DISPOSABLE PAPILLOTOMY KNIFE (WIRE GUIDED TYPE)		
	Pull type	Pull type	Pull type	Pull type (clever cut)
	TJF-160VR	KD-6G10Q-1*1 to 6G19Q-1*1	KD-200Q*1	KD-201Q*1

\*1 These accessories shows the endo-therapy applicable to guidewire of  $\varnothing$  0.89 mm (0.035 inch) diameter.

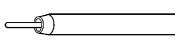
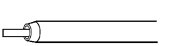
\*2 These accessories may not be available in some area.

Endoscope	DISPOSABLE PAPILOTOMY KNIFE (WIRE GUIDED TYPE)	TRIPLE LUMEN SPHINCTEROTOME	DISPOSABLE TRIPLE LUMEN SPHINCTEROTOME	
	Pull type (clever cut)	Pull type	Pull type	Pull type (clever cut)
				
TJF-160VR	KD-211Q* <sup>1</sup>	KD-301Q* <sup>1</sup> /321Q	KD-401Q* <sup>1</sup> /421Q	KD-411Q* <sup>1</sup> /431Q

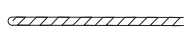
Endoscope	PRECUTTING KNIFE		SINGLE USE TRIPLE LUMEN NEEDLE KNIFE
	Needle type	Flat type	
			
TJF-160VR	KD-10Q-1	KD-11Q-1	KD-441Q* <sup>1</sup>

Endoscope	DISPOSABLE GUIDEWIRE		
	Coil type	Hybrid type	
			
TJF-160VR	G35-2LB/2LD	G-205-3545S	G-205-3545A

\*1 These accessories shows the endo-therapy applicable to guidewire of  $\varnothing$  0.89 mm (0.035 inch) diameter.

## EMC information

This model is intended for use in the electromagnetic environments specified below. The user and the medical staff should ensure that it is used only in these environments.

### ○ Magnetic emission compliance information and recommended electromagnetic environments

Emission standard	Compliance	Guidance
RF emissions CISPR 11	Group 1	This instrument uses RF (Radio Frequency) energy only for its internal function. Therefore, its RF emissions are very low and are not likely to cause any interference in nearby electronic equipment.
Radiated emissions CISPR 11	Class B	This instrument's RF emissions are very low and are not likely to cause any interference in nearby electronic equipment.
Main terminal conducted emissions CISPR 11		
Harmonic emissions IEC 61000-3-2	Class A	This instrument's harmonic emissions are low and are not likely to cause any problem in the typical commercial power supply connected to this instrument.
Voltage fluctuations/flicker emissions IEC 61000-3-3	Complies	This instrument stabilizes its own radio variability and has no affect such as flicker in lighting apparatus.

## ○ Electromagnetic immunity compliance information and recommended electromagnetic environments

Immunity test	IEC 60601-1-2 test level	Compliance level	Guidance
Electrostatic discharge (ESD) IEC 61000-4-2	Contact: $\pm 2, \pm 4, \pm 6$ kV  Air: $\pm 2, \pm 4, \pm 8$ kV	Same as left	Floors should be made of wood, concrete, or ceramic tile that hardly produces static. If floors are covered with synthetic material that tends to produce static, the relative humidity should be at least 30%.
Electrical fast transient/burst IEC 61000-4-4	$\pm 2$ kV for power supply lines  $\pm 1$ kV for input/output lines	Same as left	Mains power quality should be that of a typical commercial (original condition feeding the facilities) or hospital environment.
Surge IEC 61000-4-5	Differential mode: $\pm 0.5, \pm 1$ kV  Common mode: $\pm 0.5, \pm 1, \pm 2$ kV	Same as left	Mains power quality should be that of a typical commercial or hospital environment.
Voltage dips, short interruptions and voltage variations on power supply input lines IEC 61000-4-11	$< 5\% U_T$ ( $> 95\%$ dip in $U_T$ ) for 0.5 cycle ----- $40\% U_T$ ( $60\%$ dip in $U_T$ ) for 5 cycle ----- $70\% U_T$ ( $30\%$ dip in $U_T$ ) for 25 cycle ----- $< 5\% U_T$ ( $> 95\%$ dip in $U_T$ ) for 5 seconds	Same as left	Mains power quality should be that of a typical commercial or hospital environment. If the user of this instrument requires continued operation during power mains interruptions, it is recommended that this instrument be powered from an uninterruptible power supply or a battery.
Power frequency (50/60 Hz) magnetic field IEC 61000-4-8	3 A/m	Same as left	It is recommended to use this instrument by maintaining enough distance from any equipment that operates with high current.

**NOTE**

$U_T$  is the AC mains power supply prior to application of the test level.

**○ Cautions and recommended electromagnetic environment regarding portable and mobile RF communications equipment such as cellular phones**

Immunity test	IEC 60601-1-2 test level	Compliance level	Guidance
			Formula for recommended separation distance ( $V_1=E_1=3$ according to the compliance level)
Conducted RF IEC 61000-4-6	3 Vrms (150 kHz – 80 MHz)	3 V ( $V_1$ )	$d = \left[ \frac{3.5}{V_1} \right] \sqrt{P}$
Radiated RF IEC 61000-4-3	3 V/m (80 MHz – 2.5 GHz)	3 V/m ( $E_1$ )	$d = \left[ \frac{3.5}{E_1} \right] \sqrt{P}$ 80 MHz – 800 MHz  $d = \left[ \frac{7}{E_1} \right] \sqrt{P}$ 800 MHz – 2.5 GHz

**NOTE**

- Where “P” is the maximum output power rating of the transmitter in watts (W) according to the transmitter manufacturer and “d” is the recommended separation distance in meters (m).
- This instrument complies with the requirements of IEC 60601-1-2: 2001. However, under electromagnetic environment that exceeds its noise level, electromagnetic interference may occur on this instrument.
- Electromagnetic interference may occur on this instrument near a high-frequency electrosurgical equipment and/or other equipment marked with the following symbol:



○ Recommended separation distance between portable and mobile RF communications equipment and this instrument

Rated maximum output power of transmitter P (W)	Separation distance according to frequency of transmitter (m) (calculated as $V_1=3$ and $E_1=3$ )		
	150 kHz – 80 MHz	80 MHz – 800 MHz	800 MHz – 2.5 GHz
	$d = 1.2\sqrt{P}$	$d = 1.2\sqrt{P}$	$d = 2.3\sqrt{P}$
0.01	0.12	0.12	0.23
0.1	0.38	0.38	0.73
1	1.2	1.2	2.3
10	3.8	3.8	7.3
100	12	12	23

## NOTE

The guidance may not apply in some situations. Electromagnetic propagation is affected by absorption and reflection from structures, objects and people. Portable and mobile RF communications equipment such as cellular phones should be used no closer to any part of this instrument, including cables than the recommended separation distance calculated from the equation applicable to the frequency of the transmitter.







©2004 OLYMPUS MEDICAL SYSTEMS CORP. All rights reserved.  
No part of this publication may be reproduced or distributed without the  
express written permission of OLYMPUS MEDICAL SYSTEMS CORP.

OLYMPUS is a registered trademark of OLYMPUS CORPORATION.

Trademarks, product names, logos, or trade names used in this  
document are generally registered trademarks or trademarks of each  
company.



# **OLYMPUS®**

Manufactured by



## **OLYMPUS MEDICAL SYSTEMS CORP.**

2951 Ishikawa-cho, Hachioji-shi, Tokyo 192-8507, Japan  
Fax: (042)646-2429 Telephone: (042)642-2111

Distributed by

## **OLYMPUS AMERICA INC.**

3500 Corporate Parkway, P.O. Box 610 Center Valley, PA  
18034-0610, U.S.A.  
Fax: (484)896-7128 Telephone: (484)896-5000

## **OLYMPUS SURGICAL & INDUSTRIAL AMERICA INC.**

One Corporate Drive, Orangeburg, N.Y. 10962, U.S.A.  
Fax: (845)398-9444 Telephone: (845)398-9400

## **OLYMPUS LATIN AMERICA, INC.**

5301 Blue Lagoon Drive, Suite 290 Miami, FL 33126-2097, U.S.A.  
Fax: (305)261-4421 Telephone: (305)266-2332



## **OLYMPUS MEDICAL SYSTEMS EUROPA GMBH**

(Premises/Goods delivery) Wendenstrasse 14-18, 20097 Hamburg, Germany  
(Letters) Postfach 10 49 08, 20034 Hamburg, Germany Telephone: (040)237730



## **KEYMED LTD.**

KeyMed House, Stock Road, Southend-on-Sea, Essex SS2 5QH, United Kingdom  
Fax: (01702)465677 Telephone: (01702)616333

## **OLYMPUS MOSCOW LIMITED LIABILITY COMPANY**

117071, Moscow, Malaya Kaluzhskaya 19, bld. 1, fl.2, Russia  
Fax: (095)958-2277 Telephone: (095)958-2245

## **OLYMPUS (BEIJING) SALES & SERVICE CO.,LTD.**

Room 1202, NCI Tower, A21 Jianguomenwai Avenue Chaoyang  
District Beijing 100022 PRC  
Fax: (10)6569-3545 Telephone: (10)6569-3535

## **OLYMPUS KOREA CO.,LTD.**

8F, Hyundai Marines Bldg., 646-1, Yeoksam-Dong, Kangnam-Gu, Seoul 135-080 Korea  
Fax: (02)6255-3499 Telephone: (02)1544-3200

## **OLYMPUS SINGAPORE PTE LTD.**

491B, River Valley Road #12-01/04, Valley Point Office Tower, Singapore 248373  
Fax: 6834-2438 Telephone: 6834-0010

## **OLYMPUS AUSTRALIA PTY. LTD.**

31 Gilby Road, Mount Waverley, VIC., 3149, Australia  
Fax: (03)9543-1350 Telephone: (03)9265-5400

